



ALTERRA

WAGENINGEN UR



# Dutch Environmental Risk Indicator for Plant Protection Products

NMI 3

Alterra Report 2250.1  
ISSN 1566-7197

R. Kruijne, A.M.A. van der Linden, J.W. Deneer, J.G. Groenwold and E.L. Wipfler



---

Dutch Environmental Risk Indicator for Plant  
Protection Products

---

---

Commissioned by the Dutch Ministry of Economic affairs, Agriculture and Innovation  
Project code: [BO-12.07-004-008]

---

---

# Dutch Environmental Risk Indicator for Plant Protection Products

NMI 3

R. Kruijne<sup>1</sup>, A.M.A. van der Linden<sup>2</sup>, J.W. Deneer<sup>1</sup>, J.G. Groenwold<sup>1</sup> and E.L. Wipfler<sup>1</sup>

<sup>1</sup> Alterra, Wageningen UR

<sup>2</sup> Institute for Public Health and the environment/RIVM

## **Alterra Report 2250.1**

Alterra, part of Wageningen UR  
Wageningen, 2012

---

## Abstract

Kruijne, R., A.M.A. van der Linden, J.W. Deneer and J. G. Groenwold and E.L. Wipfler, 2011. Dutch Environmental Risk Indicator for Plant Protection Products. Wageningen, Alterra-report 2250.1, 84 pp.; 18 fig.; 15 tab.; 31 ref.

The NMI 3 focusses on indicators for emissions to surface water and the related aquatic risk resulting from agricultural use of pesticides in the Netherlands. The risk indicator is the exposure toxicity ratio. The model also considers the risk to groundwater, soil organisms and the terrestrial ecosystem. The model calculates indicators for emission to surface water resulting from atmospheric deposition, spray drift, drainage flow, point sources, discharge from greenhouses. The model combines a wide range of information about pesticide sales, usage, spray drift mitigation, emission factors, crop maps, surface water, soil, climate, and substance properties. The primary goal is to compare on a relative scale the annual risk at national scale at the starting and end year of the policy period. The results can be used for ranking, for comparing applications of similar type and for visualisation of spatial patterns of indicators. The result cannot be translated into a risk at a specific location and time.

Keywords: risk indicator, environment, sustainable use, pesticides, policy evaluation, NMI.

ISSN 1566-7197

The pdf file is free of charge and can be downloaded via the website [www.alterra.wur.nl](http://www.alterra.wur.nl) (go to Alterra reports). Alterra does not deliver printed versions of the Alterra reports. Printed versions can be ordered via the external distributor. For ordering have a look at [www.rapportbestellen.nl](http://www.rapportbestellen.nl).

© 2012 Alterra (an institute under the auspices of the Stichting Dienst Landbouwkundig Onderzoek)  
P.O. Box 47; 6700 AA Wageningen; The Netherlands, [info.alterra@wur.nl](mailto:info.alterra@wur.nl)

- Acquisition, duplication and transmission of this publication is permitted with clear acknowledgement of the source.
- Acquisition, duplication and transmission is not permitted for commercial purposes and/or monetary gain.
- Acquisition, duplication and transmission is not permitted of any parts of this publication for which the copyrights clearly rest with other parties and/or are reserved.

Alterra assumes no liability for any losses resulting from the use of the research results or recommendations in this report.

**Alterra Report 2250.1**

Wageningen, January 2012

# Contents

Preface	7
Summary	9
1 Introduction	11
1.1 General introduction	11
1.2 Overview of applications methods and emission pathways	13
1.3 Readers guide	16
2 Input data	17
2.1 Usage data	18
2.2 Geographical data	19
2.3 Emission factors	22
2.4 Substance data	23
3 Emission indicators	26
3.1 Crop interception, volatilisation and net soil deposition	26
3.2 Surface water	30
3.2.1 Atmospheric deposition	30
3.2.2 Spray drift	33
3.2.3 Drainage flow	40
3.2.4 Point sources	43
3.2.5 Discharge from greenhouses with soilless cultivation	44
3.2.6 Emission from greenhouses with soil bound cultivation	50
3.3 Groundwater	52
3.4 Air	56
4 Exposure	59
4.1 Surface water	59
4.1.1 Spray drift, atmospheric deposition and point sources	60
4.1.2 Greenhouses and drainage	61
4.1.3 Exposure concentration in water	63
4.1.4 Dissipation in water	64
4.2 Groundwater	65
4.3 Exposure concentrations for soil organisms	65
4.4 Exposure concentrations for terrestrial organisms (birds)	70
4.4.1 Spraying applications	71
4.4.2 Granular applications	71
4.4.3 Seed treatment	72

5	Risk indicators and aggregation	75
5.1	Surface water	75
5.1.1	Acute toxicity	75
5.1.2	Chronic toxicity	75
5.2	Groundwater	76
5.3	Soil organisms	76
5.3.1	Acute toxicity	76
5.3.2	Short-term chronic toxicity	76
5.3.3	Medium term toxicity (two years)	77
5.3.4	Long term toxicity (seven years)	77
5.4	Terrestrial ecosystem (birds)	77
5.4.1	Acute toxicity	77
5.4.2	Chronic toxicity	78
5.5	Aggregation over plots	78
5.6	Trends	79
6	Discussion and conclusions	81
	References	83



# Preface

The Dutch policy on sustainable crop protection is subject to evaluation at the end of the current, 2<sup>nd</sup> policy period 1998-2010. A mid-term evaluation was conducted in 2006, using the Dutch Pesticide Risk Indicator NMI 2 to calculate the risk reduction during the first part of the policy period. On behalf of the Dutch Ministry of Economic affairs, Agriculture and Innovation and the Dutch Ministry of Infrastructure and Environment, a new model version NMI 3 was developed, to support the end evaluation of the policy document on sustainable crop protection by calculating the aquatic risk reduction during the entire policy period. The NMI 3 was developed in cooperation between Alterra, part of Wageningen UR and the Institute for Public Health and the Environment (RIVM). The project was carried out within the framework of Research Theme BO-12.07-004, project number 008, and with contributions from the Statutory Research Tasks Unit for Nature & the Environment (WOT Natuur & Milieu). The scientific panel met with the project leaders from Alterra and RIVM twice per year, to discuss the implementation of new models in the NMI 3 and, at a later stage, to review the report. The review of the scientific panel was restricted to the text of the report. The members of the scientific panel are: Dr. Ir. J.J.T.I. Boesten, Dr. Ir. A. Tiktak, Prof. Dr. Ir. P van den Brink, Dr. Ir. D. de Zwart, and Dr. Ir. G. B. M. Heuvelink.

New emission models for the NMI 3 are based on tools which were recently developed for use in registration. A new version of the NMI database was made, which contains all input data about pesticide usage and crop maps in three survey years, emission factors, surface water, soil and meteorological data, and substance properties. The models for the risk to soil organisms and the terrestrial ecosystem were updated on behalf of the Environmental Assessment Agency and funded by the Dutch Ministry of Economic Affairs, Agriculture and Innovation. This report describes the concepts, the methodology and the scope of the indicators built in the NMI 3. The results for the evaluation of the policy document on sustainable crop protection are described in (Van der Linden et al., 2012. *in preparation*).

Many persons have contributed to the development of the new version NMI 3, and we wish to thank the following colleagues in particular:

- Aaldrik Tiktak (PBL) for providing the drainage emission factors based on simulations with the GeoPEARL 4 model.
- Jan van de Zande, Henk-Jan Holterman and Jan Huijsmans (PRI, part of Wageningen UR) for providing the spray drift emission factors and for reviewing the drift module of the NMI 3.
- Eric van Os (WUR-PRI), for providing the daily water balances for greenhouse crops with soilless cultivation.
- Paul Oljans (CBS) for providing the crop statistics and Nanny Heidema (Alterra) for preparing the land-use data.
- Ariëne Matser for converting restriction data into the NMI 3 database.
- Annet Bulle (WUR-PPO), Marieke van der Staaij (WUR-Greenhouse Horticulture), H. Boesveld, M. van IJzendoorn and Ton Rotteveel (nVWA) for reviewing the coupling between the usage from surveys conducted by Statistics Netherlands and the applications methods available in the NMI 3.
- Rob Vijftigschild and Remko Holtkamp (CBS) and Jacob Jager (LEI, part of Wageningen UR) for providing the usage data.
- Joost Vlaming (Envista Consultancy) for programming the modules for greenhouse crops with soilless cultivation, and Wim de Winter and Rob Lokers for their IT-related advice.

Roel Kruijne  
John Deneer  
Ton van der Linden  
Jan Groenwold  
Louise Wipfler



# Summary

The crop protection policy of the Dutch Government is subject to evaluation of the current, 2<sup>nd</sup> policy period 1998 - 2010. A mid-term evaluation was conducted in 2006 for the 1<sup>st</sup> part of the policy period, using the Dutch Pesticide Risk Indicator NMI 2 to calculate risk reduction for the aquatic ecosystem. On behalf of the Dutch Ministry of Economic affairs, Agriculture and Innovation, and the Dutch Ministry of Infrastructure and Environment, the new model version NMI 3 was developed in the period 2009 - 2011 to support the end evaluation of the crop protection policy (EDG-2010). This report describes the concepts and the methodology of the NMI 3.

The NMI 3 focusses on the emissions to surface water and the related risk to the aquatic ecosystem. The use of pesticides may also lead to contamination and risk to other parts of the environment, such as groundwater, soil organisms and the terrestrial ecosystem. Although the Dutch policy document contains no additional operational targets for these environmental compartments, the risks are considered in the evaluation as well and therefore the NMI 3 also contains modules for calculating these risk indicators.

The NMI 3 includes modules for calculating emission to surface water resulting from atmospheric deposition, spray drift, drainage flow, point sources, and discharge from greenhouses with soilless cultivation and from greenhouses with soil bound cultivation. The model is comprised of a number of simple models, combining a wide range of information about pesticide usage, emission factors, the geographical distribution of crops, surface water, soil and climate properties, and substance properties. Each application in the NMI database is linked to a combination of object treated and application method which determines the emission pathways calculated.

The primary goal of the NMI 3 is to produce a trend line connecting two points of the annual environmental risk at national scale level, at the starting and end year of the policy period 1998-2010. Each point represents the risk indicator outcomes in the years corresponding with farm based surveys conducted by Statistics Netherlands (CBS). For surface water, the value of the exposure toxicity ratio at a specific location and time does not express the level of risk. The results can also be used for ranking, for comparing applications of similar type and for visualisation of spatial patterns in calculated emission indicators and risk indicators.

Substance data in the NMI 3 are based on data recorded by Ctgb and water quality standards obtained from the Helpdesk Water website ([www.helpdeskwater.nl](http://www.helpdeskwater.nl)). The latter data are used for the evaluation of the Dutch crop protection policy. The NMI substance database contains physico-chemical, fate and ecotox parameters of plant protection products (PPP) and metabolites, derived from EU and Dutch authorisation dossiers.

Pesticide usage is described in the model in terms of national average applications. These applications are prepared from farm based survey data and from additional information on the implementation of drift reducing measures and on the use restrictions prescribed by the Dutch registration authority Ctgb. The resulting national average applications in the model differ from real applications according to the product label, with respect to the rate applied, the application date, and the number of treatments. The whole of national average applications in a particular model crop cannot be compared with common crop protection activities at individual farms, because all crop locations in the model are treated (at an adjusted rate) with any substance applied at one or more of the farms represented in the survey.

Use of national average applications implies that the calculated exposure concentration cannot be directly compared with a safe concentration. Although the calculated exposure for a particular application is expressed as a concentration, it does not represent a percentile exposure concentration at the edge of field scale which can be used in registration procedures. For this reason the exposure toxicity ratio type of risk indicator is preferred for use in support of policy evaluations. A distance to target type of risk indicator is based on the difference between the calculated exposure and the safe concentration and would in principle be a better choice for policy evaluations. The available statistical data and some of the emission models in the NMI 3 are not targeted for calculating such an indicator and therefore in this case the distance to target is not considered as a suitable type of indicator to support the evaluation of a policy plan.

Some of the emission models in the NMI 3 are derived from tools which were developed for use in registration, whereas other models are based on simple worst case scenarios. Summation of risk indicator units over different combinations of object treated and application methods, calculated using dissimilar models, may result in misleading conclusions about the relative importance of these combinations. Whereas the NMI 2 only calculated the chronic risk indicator for spray drift resulting from applications in arable crops, the NMI 3 calculates the chronic risk indicator for all combinations of object treated and application method in the usage data. Because of differences in concepts and the available datasets, trends should be derived only within groups of applications which belong to the same combination of object treated and application method.

Summation of risk indicator units over different combinations of object treated and application methods, calculated using dissimilar models, may result in misleading conclusions about the relative importance of these combinations. On the other hand, the national policy evaluation explicitly requires a single aggregated trend as a result of all agricultural applications. The best option in such cases is to aggregate the risk resulting from all applications in arable crops, and separately aggregating the applications in greenhouse crops with soilless cultivation and in greenhouse crops with soil bound cultivation. These greenhouse crop groups do not include mushroom cultivation. As already pointed out previously, we do not advocate such summation of indicators calculated with dissimilar models.

# 1 Introduction

## 1.1 General introduction

The main goal of the Dutch governmental policy on sustainable crop protection is to ensure that the aquatic risk resulting from the use of pesticides (plant protection products) are minimised. Because the environmental quality of Dutch surface waters does not meet the water quality standards, the Dutch policy document on sustainable crop protection contains an operational target for aquatic risk reduction with 95% during the policy period 1998 - 2010.

The crop protection policy is subject to evaluation at the end of the current, 2<sup>nd</sup> policy period. A mid-term evaluation was already conducted in 2006 (MNP, 2006), using the Dutch Pesticide Risk Indicator NMI 2 to calculate the risk reduction during the first part of the policy period. On behalf of the Dutch Ministry of Economic affairs, Agriculture and Innovation, and the Dutch Ministry of Infrastructure and Environment, a model version NMI 3 was developed to support the end evaluation of the crop protection policy (EDG-2010). This report describes the concepts and the methodology of the NMI 3. The results of the calculations for the evaluation of the crop protection policy are described in Van der Linden et al., 2012, in preparation.

The use of pesticides may also lead to contamination and risk to other parts of the environment, such as groundwater, soil organisms and the terrestrial ecosystem. Although the Dutch policy document contains no additional operational targets for these environmental compartments, the risks are considered in the evaluation as well and therefore the NMI 3 also contains modules for calculating these risk indicators.

The NMI comprises of a number of simple models, combining a wide range of information about pesticide usage, emission factors, the geographical distribution of crops, surface water, soil and climate properties, and substance properties, with the purpose of calculating emissions to environmental compartments and the related environmental risk. Some of these models are derived from tools which were developed for use in authorisation; the emission factors used in these models are usually based on 90<sup>th</sup> percentile exposure scenarios. Other models not developed for use in authorisation procedures are usually based on worst case scenarios.

The general calculation scheme is subdivided into four steps (Figure 1):

1. Calculation of the emissions (in kg) towards several environmental compartments.
2. Calculation of the environmental concentration for each of the compartments, by conversion of the emissions (for surface water, groundwater), based on the soil deposition rate (for soil organisms), or based on the usage (for the terrestrial ecosystem).
3. Calculation of risk as the ratio of exposure concentration and toxicity (or quality standard), either acute or chronic.
4. Aggregation, i.e. the summation of emission indicators and risk indicators for individual applications.

The first three steps are performed for each individual application described in the usage data, and for all locations contributing to the national crop area. Since the exposure concentration and the corresponding aquatic risk indicators depend on the field ditch dimensions, exposure and risk are calculated for each spatial unit of the soil hydrological schematisation of the Netherlands (these spatial units are referred to as plots, and will be described in Section 2.2). The results per application plot combination are stored in external output files; i.e. one file per crop and substance combination, with the emission indicators and risk indicators

expressed per unit area of agricultural land. In step 4 these indicators per unit area are multiplied with the crop area per plot and the sum is calculated for all plots contributing to the national crop area. The resulting indicators for national average applications can be summed for group(s) of applications, e.g. per combination of object treated and application method (Section 1.2), substance, or crop (group).

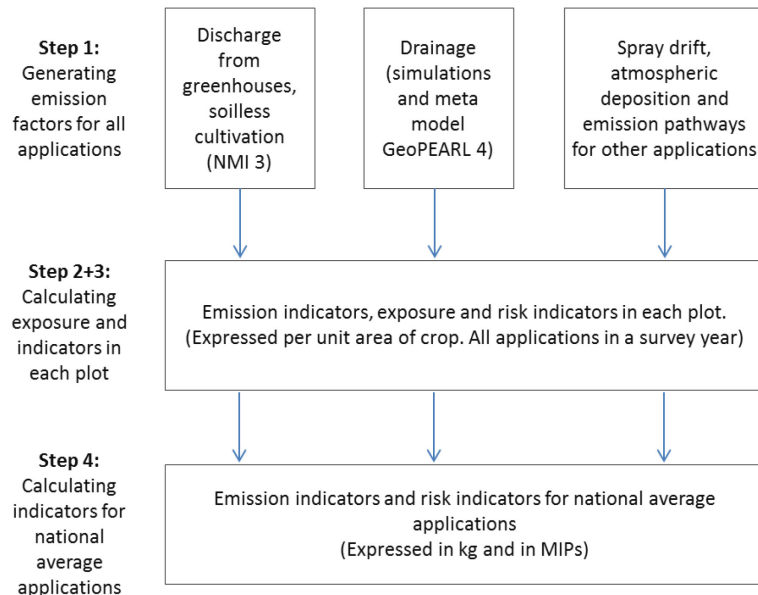
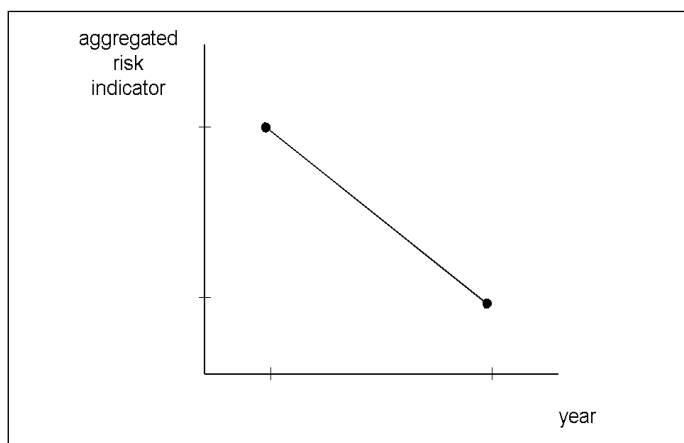

**Figure 1**  
Scheme showing the calculations for one national survey year in three steps.

The primary goal of the NMI 3 is to produce a trend line connecting points of the annual environmental risk resulting from the agricultural use of pesticides. Each point represents (the sum of) the risk indicator outcomes obtained for individual applications at the starting or end year of the evaluation period (Figure 2). These years correspond with the farm based surveys conducted by Statistics Netherlands (CBS). The outcomes can also be used for ranking the environmental risk resulting from (groups of) applications and for visualisation of spatial patterns in calculated emission indicators and risk indicators.

Although the calculated exposure for a particular application is expressed as a concentration ( $M L^{-3}$ ), it does not in fact represent a percentile exposure concentration at the edge of field scale, and therefore it cannot be used for comparison with a decision criterion. For surface water, the value of the exposure toxicity ratio at a specific location and time does not express the level of risk. The NMI 3 contains routines to calculate distance to target indicators, i.e. it has possibilities to compare exposure concentrations with safe concentrations and to take only the exceedances into account in further calculations and aggregations. The information as gathered by Statistics Netherlands and the schematisation that is used for the calculations, however, are not very suitable for calculating such distance to target indicators. Additional information on the usage would be necessary as well as a more field targeted schematisation and way of calculation. For this reason this type of risk indicator is considered not suitable to support the evaluation of the policy plan.

The NMI 3 is intended for use at the national scale level. Because uncertainties in the input data can have a large effect on outcomes at the local scale, results at this scale level should not be used for policy evaluations (local scale level is defined here as the size of a plot). At the national scale, uncertainties average out and results are more trustworthy. The effect of uncertainties in the input data on the results at regional scale levels was not investigated.



**Figure 2**  
Trend line connecting points of aggregated annual environmental risk.

## 1.2 Overview of applications methods and emission pathways

The emission models built into the NMI 3 cover the major agricultural applications in terms of usage, crop area and possible emission routes. Most of these models are derived from recently developed scenarios and tools intended for use in Dutch and/or European registration, e.g. the exposure assessment for aquatic organisms resulting from spray drift and drainage (Zande et al., 2012, Tiktak et al., 2012a), and the exposure assessment for soilless cultivation in greenhouses (Vermeulen et al., 2010). Other emission models still originate from the evaluation of the previous, 1<sup>st</sup> policy period (De Nie et al., 2002). Non-agricultural use and the resulting emission, such as run-off from paved area, is not included in the NMI 3.

The combination of object treated and application method determines which emission models are selected for calculating the indicators. Each application belongs to one of the categories shown in Table 1. The application method in NMI 3 may refer to the object treated (soil, crop, plant material, or harvested products), the location (arable field, greenhouse, farm yard or storage building), the equipment and the formulation of the product.

Table 2 shows the emission pathways to surface water calculated for each combination of object treated and application method. For field spraying applications (1, 12) atmospheric deposition, spray drift and drainage flow are calculated. Because the emission factors for atmospheric deposition and spray drift do not apply to spraying with a knapsack (13), only drainage flow is considered for this combination of application method and object treated. Treatment of plant material (4) and harvested products in storage buildings (3) may lead to run-off from the farm yard or by discharge of condensation water. This kind of losses is referred to as point source emissions. Different application methods in greenhouse crops with soilless cultivation (7, 8, 9) may lead to discharge of water and dissolved substances, whereas applications in greenhouse crops rooting in soil (5) may lead to emission by drainage flow (leaching) and by discharge. Finally, applications in mushrooms cultivation may lead to discharge of condensation water collected inside cultivation buildings (10).

**Table 1**

Categories of object treated and application method, determining the selection of emission models in the NMI 3.

Description of application method #	Object treated		
	Soil	Crop	Plant material, harvested products
Spraying with field sprayer boom (1)	X	X	
Soil incorporation, soil injection and granular application (2)	X		
Spraying followed by soil incorporation (12)	X		
Local field spraying (knapsack) (13)		X	
Seed treatment in arable crops (6)			X
Treatment in storage buildings (3)			X
Treatment at farm yards (4)			X
Application along with the recirculated nutrient solution (A, 9)		X	
Spraying, fogging or fumigating greenhouse crops; soilless cultivation with roots shielded (B, 8)		X	
Spraying, fogging or fumigating greenhouse pot plants standing on flooding tables (C, 7)		X	
Spraying, fogging or fumigating greenhouse crops rooting in soil (D, 5)	X	X	
Application in mushroom cultivation buildings (10)		X	

# with the internal code (1) .. (13) or (A, ..., D) between brackets.

**Table 2**

Emission indicators selected for each category of object treated and application method, for surface water (field ditches) (NMI 3).

Application method and object treated	Emission pathway to surface water					
	Atmospheric deposition	Spray drift	Drainage flow	Leaching	Point sources	Discharge from green-houses
Spraying with field sprayer boom (1)	X	X	X			
Soil incorporation, soil injection, and granular application (2)						
Spraying followed by soil incorporation (12)	X	X	X			
Local field spraying (knapsack) (13)			X			
Seed treatment in arable crops (6)						
Treatment in storage buildings (3)					X	
Treatment at farm yards (4)					X	
Application along with the recirculated nutrient solution (A, 9)						X
Spraying, fogging or fumigating greenhouse crops; soilless cultivation with roots shielded (B, 8)						X
Spraying, fogging or fumigating greenhouse pot plants standing on flooding tables (C, 7)						X
Spraying, fogging or fumigating greenhouse crops rooting in soil (D, 5)				X	X	
Application in mushroom cultivation buildings (10)					X	



Table 3 shows which emission indicators for the environmental compartments groundwater, air, soil and the terrestrial ecosystem are linked to each of the combinations of object treated and application method. Emission to groundwater is calculated for spraying applications and for granular applications in arable crops (1, 2, 12, 13) and for soil bound cultivation in greenhouses (5). Emission to air is calculated for spraying applications in arable crops and in greenhouse crops. Exposure to soil organisms is calculated for spraying applications and for granular applications in arable crops. Finally, the exposure of the terrestrial ecosystem in terms of the food intake by birds is calculated for applications in arable crops, notably spraying applications (1, 12, 13), Soil incorporation, soil injection, and granular application (2), and seed treatment (6).

**Table 3**

*Emission indicators selected for each category of object treated and application method, for groundwater, air, soil and the terrestrial ecosystem (NMI 3).*

Application method and object treated	Environmental compartment			
	Groundwater	Air	Soil	Terrestrial ecosystem
Spraying with field sprayer boom (1)	X	X	X	X
Soil incorporation, soil injection, and granular application (2)	X		X	X
Spraying followed by soil incorporation (12)	X	X	X	
Local field spraying (napsack) (13)	X	X		X
Seed treatment in arable crops (6)				X
Treatment in storage buildings (3)				
Treatment at farm yards (4)				
Application along with the recirculated nutrient solution (A, 9)				
Spraying, fogging or fumigating greenhouse crops; soilless cultivation with roots shielded (B, 8)		X		
Spraying, fogging or fumigating greenhouse pot plants standing on flooding tables (C, 7)		X		
Spraying, fogging or fumigating greenhouse crops rooting in soil (D, 5)	X	X		
Application in mushroom cultivation buildings (10)				

In lack of more recent data and developments, the emission modules for treatment of plant material (4), for soil bound greenhouse crops (5) and for mushrooms cultivated in buildings (10) were taken from concepts that were developed for the evaluation of the 1<sup>st</sup> policy plan (MJP-G; De Nie, 2002; Van der Linden et al., 2006) and were subsequently used in the NMI 2 for the mid-term evaluation of the current policy plan. The NMI 2 calculated the aquatic risk indicators resulting from field spraying applications only. The new NMI 3 calculates the aquatic risk indicator for all the applications mentioned in Table 2. The emission indicators are expressed in amount of active ingredient (substance) per year. The modules for drainage flow and for leaching can also calculate the emission indicators for the metabolites in the substance database. In the output of the NMI 3, the emission amounts and the calculated risks of the parent substance and the metabolite(s) are lumped and reported under the name of the parent.

### **1.3 Readers guide**

Chapter 2 gives an overview of the input data required for calculating the risk indicators. Chapter 3 describes the calculation of soil deposition and the various emission pathways resulting from applications in arable crops and greenhouse crops. The conversion of emissions into exposure concentrations is described in Chapter 4, and the corresponding risk indicators in Chapter 5. In Chapter 5 we explain how the results are aggregated from the spatial units of the hydrological schematisation to the national scale level, to obtain the indicators for national average applications. The scope of the model instrument is discussed in Chapter 6.

The appendices referred to in this report are put in a separate document. These include maps and details on the NMI input data, and the simulation model for emissions resulting from applications in greenhouse crops with soilless cultivation, and an additional literature search conducted in the framework of the Statutory Research Tasks Unit for Nature & the Environment. The outcome of the calculations for the 2<sup>nd</sup> Dutch policy plan are described in EDG-Milieu, (Van der Linden et al., 2012, in preparation).

## 2 Input data

This Chapter contains an overview of the major components of the NMI database. In order to calculate the risk indicators at the start, the mid-term and the end year of the evaluation period, the NMI database contains input data on the following topics (Figure 3):

- usage during the evaluation period of the Dutch crop protection policy document,
- geographical data,
- emission factors for different pathways, and
- substance properties.

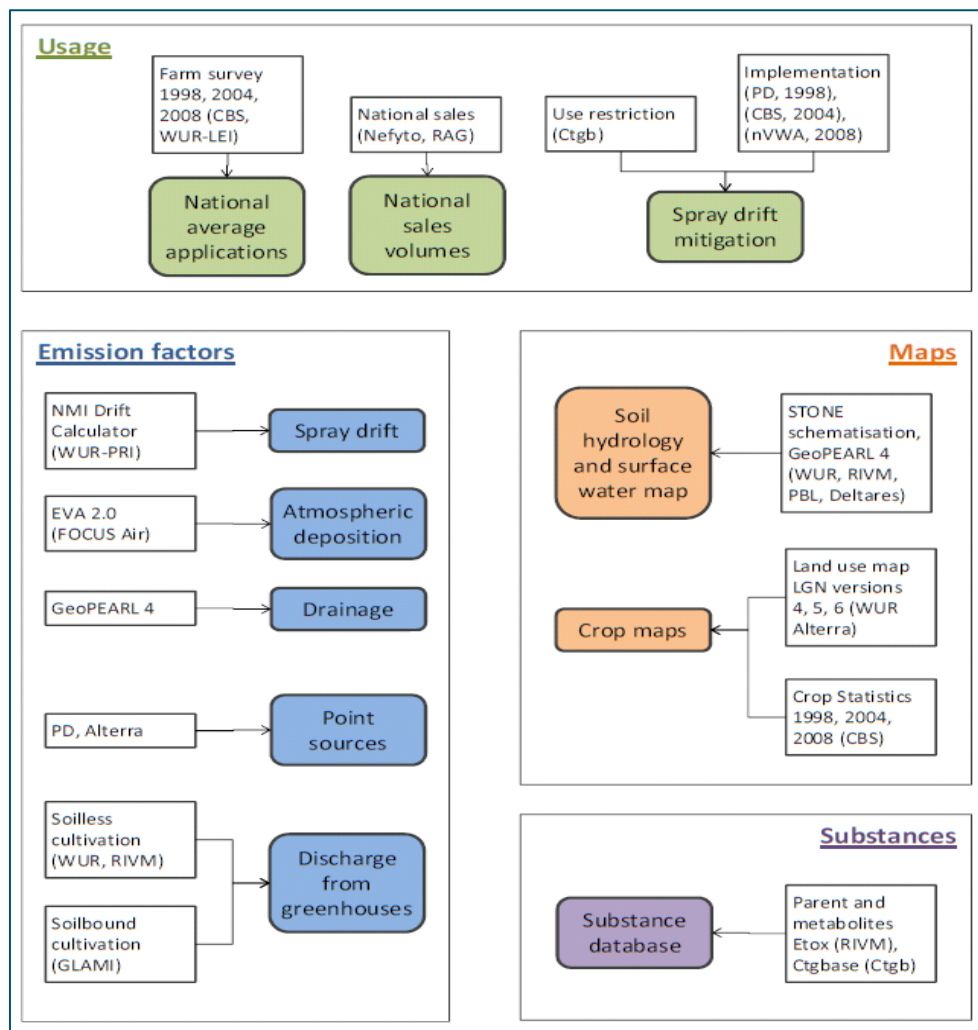

**Figure 3**

The NMI 3 input consists of pesticide usage, substance data, emission factors, and maps. The major database components are shown in colour and the external sources in white.

## 2.1 Usage data

The scope of agricultural use in the NMI 3 is in line with the surveys conducted by Statistics Netherlands (CBS). This includes treatments of crop, soil, plant material and harvested product at the farm. Other types of applications (e.g. biocides) and uses by other groups (consumers, private companies, public authorities) are not considered. Regional use patterns within the Netherlands are not available; the surveys conducted for the years 1998, 2004 and 2008 are representative of the entire population of farms in the Netherlands and the criteria for this representativeness are set by Statistics Netherlands. It is assumed that all applications in the NMI 3 have taken place at the location of the field or the greenhouse, which is also assumed to be the location of the farm yard and storage buildings.

The surveys include the major annual and perennial arable crops, excluding grassland, and the major greenhouse crops. Usage data in grassland is obtained from the Agricultural Economics Research Institute (WUR-LEI, BedrijvenInformatieNet/BIN). Both sources together cover approximately 95% of the total area of agricultural crops in the Netherlands. The farm based applications are specified by the Dutch registration code, the volume applied, the fraction of the crop area treated and the application date. Before the survey data can be used in the model, the farm based product applications have to be transformed into national average applications in terms of active ingredients. In the model each national average application is defined by the survey year, the parent substance, the object treated, the application method and technique, the application rate (for all treatments within the application; in kg ha<sup>-1</sup>), the application time (month), the number of treatments, and the time interval between treatments. The volume applied at the area treated is converted into an application rate (the amount of substance per unit of crop area). Based on the Dutch registration code, farm based applications are associated with a combination of object treated and application method in the model. Average values for the application rate and the fraction of the area treated are calculated for groups of similar, farm based applications. The maximum number of treatments is set equal to four and the interval between treatments is set equal to seven days. Usage which occurs during a longer period is divided over a number of national average applications, each with another application time (month).

The amount of substance applied at the farms is distributed in the model among the entire crop area in the Netherlands. Since most types of usage are actually performed by only a fraction of the farms present in the survey, the national average application rate in the model input decreases with the corresponding fraction of the national crop area treated. These national average applications imply that all locations with the crop get the same treatment. As a consequence, the application rate in the model will be lower than the dose rate applied by the farmers. Also, the whole of all national average applications in a particular crop does not reflect common crop protection plans.

For the evaluation of the current, 2<sup>nd</sup> policy plan (EDG-2010), the national volume applied according to the survey data is adjusted for the national sales volume. These sales data for the Dutch market are provided by the Dutch Crop Protection Agency, on a confidential base for use within the EDG-2010. Average sales volumes at the survey years were derived from the annual figures as shown in Table 4. For most substances the national sales volume exceeds the national volume according to the survey, so this adjustment leads to an increase of the (national average) application rate.

**Table 4**

*Combinations of usage (surveys by Statistics Netherlands) and sales data at the evaluation period of the Dutch policy plan for sustainable crop protection (EDG-2010).*

Period	Usage (survey)	Sales volumes
Start year	1998	1997-1999
Mid-term	2004	2004-2005
End year	2008	2008-2010

The degree to which drift reducing nozzles or buffer zones were used in order to reduce drift is expressed by means of the implementation degree. This information in the year 1998 is based on (Wingelaar et al., 2001), in the year 2004 on an additional survey (Statistics Netherlands, CBS, 2005), and in the year 2008 on a survey conducted by nVWA (Mol and Wingelaar, 2010). The implementation degree of drift reducing measures is available per arable crop, for the relevant technique (nozzles and other equipment) and crop free zone and with a distinction between two spaying directions (upward- and sideward, or downward). In fruit orchards the implementation degree applies both to the dormant stage and to the full leaf stage of the wind screen (the full leaf stage starts in May and lasts until October). For both stages different drift emission factors can be used.

Use restrictions are prescribed for particular products and crops (registrations) by the Dutch registration authority Ctgb. A separate database with restrictions was obtained from the Ctgb. Restrictions for spray drift which specify the minimum drift reduction class were combined with the national average applications from the survey and the drift emission factors in the NMI 3.

## 2.2 Geographical data

In the model surface water is considered as a field ditch with regional average dimensions and with standing water conditions.

The NMI 3 uses the STONE schematisation for calculating the emission and risk indicators (Kroon et al., 2003, Kroes et al., 2002). This soil hydrological schematisation covers the rural area of the Netherlands ( $2.8 \cdot 10^6$  ha) and contains 6405 different plots ranging in size from 25 to 21763 ha. The median plot size = 288 ha. The plots are built of elements with the size of 250 m x 250 m (6.25 ha cells) and are unique by its combination of soil, surface water, soil hydrology and climate properties. The properties used for calculating the indicators are shown in Table 5.

**Table 5**

*Properties of the soil hydrological schematisation stored in the NMI database ([1] Kroon et al., 2003, [2] Tiktak et al., 2012b, [3] calculated, as explained in Section 3.3).*

Parameter	Units	Source
Soil pH KCl <sup>#</sup>	-	1
Soil organic matter content <sup>#</sup>	%	1
Soil dry bulk density <sup>#</sup>	kg dm <sup>-3</sup>	1
Average soil moisture content, spring season <sup>#</sup>	m <sup>3</sup> m <sup>-3</sup>	3
Average soil moisture content, autumn season <sup>#</sup>	m <sup>3</sup> m <sup>-3</sup>	3
Annual precipitation amount	m a <sup>-1</sup>	1
Annual percolation in the soil at 1 m depth	m a <sup>-1</sup>	1
Small field ditch density (tertiary class)	m ha <sup>-1</sup>	2
Medium width field ditch density (secondary class)	m ha <sup>-1</sup>	2
Large field ditch density (primary class)	m ha <sup>-1</sup>	2
Average daily temperature and long-term annual temperature	K	2
Hydrological region number (hydrotype)	-	2
Meteorological region number	-	1

<sup>#</sup> (layer 0-0.05 m, 0-0.20 m and 0-0.35 m depth).

The crop maps and the soil hydrological schematisation are available at the same spatial resolution. The crop area (in ha) within each plot is obtained from an overlay of both maps, and equals the total crop area in all the cells with the same plot number (Figure 4). The indicators are calculated for each spatial unit of the soil hydrological schematisation of the Netherlands which contributes to the national crop area. The geometry of parcels and surface watercourses is not available in the NMI 3. Since the properties of all cells within a plot are the same, the crop area per cell is not needed in the NMI 3. When generating maps in a post-processing procedure, the crop area per cell can be used.

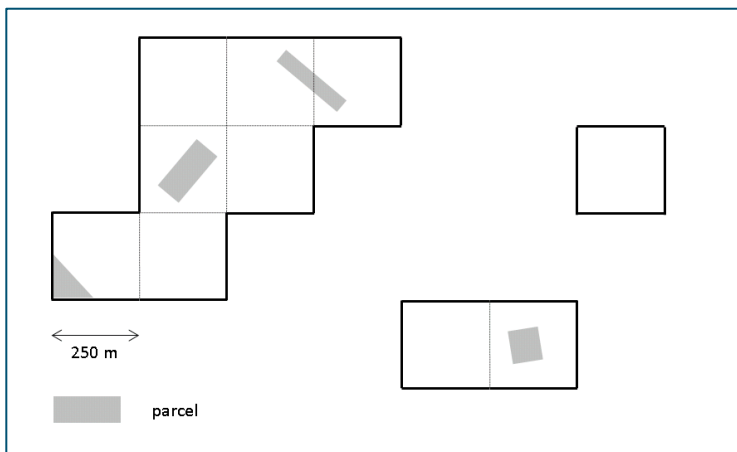

**Figure 4**

*Schematic presentation of an example unit of the soil hydrological schematisation (a plot) which is built of ten 250 m x 250 m cells. These cells have the same combination of soil, surface water, soil hydrological and meteorological properties in common. The crop area within this plot equals the total area of individual parcels. The geometry of parcels and surface water and the geographical location of the individual cells are not available in the NMI 3.*

The total length of surface watercourses in the Netherlands exceeds  $300 \cdot 10^3$  km (Van Puijenbroek and Clement, 2008). According to the STONE schematisation, some  $280 \cdot 10^3$  km of watercourses is present in the rural area of the Netherlands (Kroon et al., 2003). Information on the dimensions of watercourses is available for 3 classes of the topographical map (small, medium sized and large ditches). For the remaining watercourses with a width of the water surface  $\geq 6$  m, no such information is available and therefore these were discarded in the model GeoPEARL 4. Part of these watercourses is not located at the edge of agricultural fields. The surface water length in GeoPEARL 4 consists of the field ditches adjacent to drained agricultural land, with a width  $< 6$  m. The total length of these field ditches, represented by Group C and D in Figure 4, is equal to  $176 \cdot 10^3$  km. It is assumed in the model that half the length of ditches with pipe drain outlets can receive loadings by spray drift and atmospheric deposition ( $C : D = 1$ ). The small ditch class contains 46% of the total length, the medium ditch class 52%, and the large ditch class 2% (these figures were taken from GeoPEARL 4; the surface water maps are included in Appendix 1). Field ditches adjacent to agricultural land without pipe drainage (Group A in Figure 5) are not included in the model. On average, ditches without pipe drains (Group A) are smaller than ditches with pipe drains (Groups C and D) and the emissions by spray drift and atmospheric deposition may be higher. It was estimated that the exposure by spray drift in Group A ditches is a factor 2 higher than the exposure by spray drift in Group C ditches (Van der Zande et al., personal communication).

Field ditch length	Spray drift	No spray drift
	No drainage	A (52)
Drainage	C (88)	D (88)

**Figure 5**

*The field ditch population in the Netherlands can be divided in four groups, based on the possible deposition by spray drift onto the water surface and on the presence of pipe drains which discharge into the field ditch. The field ditches in the NMI 3 represent Group C and D. The figures denote the approximate length in  $10^3$  km<sup>3</sup> (see text).*

The average cross-sectional dimensions are available for 66 ditch profiles (three watercourse classes and 22 hydrological regions in the Netherlands). Each hydrological region consists of a number of plots, and all plots are assigned to one of these 22 hydrological regions.

The crop maps are stored in the database in terms of area per plot. There are three sets of crop maps, which were calculated based on the Land-use Map of the Netherlands (LGN versions 4, 5 and 6) and Crop Statistics

per municipality for the survey years 1998, 2004 and 2008). In these crop maps the high resolution of the land-use map is combined with the detailed crop list by Statistics Netherlands. Satellite images used for the LGN usually originate from the two years prior to the survey years ([www.lgn.nl](http://www.lgn.nl)). All crops are related to one of the agricultural land-use classes in the LGN (pasture, maize, cereals, potatoes, other arable crops, sugar beet, fruit orchards, fruit nurseries, flower bulbs, nursery trees, and greenhouses). The exception is mushroom cultivation: for this crop there is no map available.

The area of crops is related to the administrative location (municipality) of farms, whereas the location of the crop is defined by the land-use images. This may lead to deviations in the crop map at the scale level of (adjacent) municipalities, when the farm yard and the field have different locations. Another example of inaccuracies in the crop maps at regional scale is the area cultivated with flower bulbs (lilies) in the Province of Drenthe. Part of this cultivation is contracted out by farmers in the traditional flower bulb growing regions in the Province of Noord-Holland. As a consequence, the total flower bulb growing area is underestimated in the Province of Drenthe, and the area is overestimated in the Province of Noord-Holland.

## 2.3 Emission factors

### *Atmospheric deposition*

Emission by atmospheric deposition at the water surface depends the most on the vapour pressure of the active ingredient. Emission factors for atmospheric deposition are calculated using deposition functions for three vapour pressure classes (Section 3.2.1). The function parameters are stored in the database.

### *Spray drift*

Spray drift emission depends on the distance between the outer nozzle at the spraying boom and the water surface in the ditch adjacent to the field (Section 3.2.2). Spray drift emission factors are calculated with the NMI Drift calculator using drift curves applicable to the major crop groups, spraying directions, technique (nozzles and other equipment) and crop free zones. The whole of these combinations covers the Dutch agricultural practice at the beginning and at the end of the evaluation period EDG-2010. These drift crop groups are translated to the crops in the NMI 3 (Appendix 6). The distance between the outer nozzle and the water surface depends on the width of the crop free zone and on the field ditch dimensions. Each of the 66 field ditch profiles represents another section of the spray drift curve, and the 70<sup>th</sup> or 90<sup>th</sup> percentile drift emission factors were calculated for all combinations of drift curves and field ditch profiles with the NMI Drift Calculator by PRI, part of Wageningen UR.

Appendix 2 contains tables per arable crop sector and year, with the implementation degree for the combinations of crop, technique and crop free zone. Appendix 3 contains tables per arable crop sector and year, with example drift emission factors for a standard field ditch. This standard field ditch is not used in the calculations but was added to the NMI 3 database for reference only.

The drift process is independent from the substance properties and the average drift factor may be used for all substances. However, in case a restriction applies to the application, the national average drift emission factor is replaced with the drift emission factor which corresponds with the drift reduction class prescribed by the restriction. This replacement of the national average drift emission factor follows from the assumption that farmers work according to Good Agricultural Practice and that the restriction is adhered to. The restriction specifies a drift reduction class relative to the reference spraying technique.

### *Drainage*

Emission factors for drainage are available for all the plots which contribute to the area of crops. For a group of 48 substances with high leaching potential, the emission factors are obtained from simulations with the



GeoPEARL model version 4 for preferential flow through macroporous soils with pipe drainage (Tiktak et al., 2012b). The GeoPEARL model was run with four different application times. For another group of substances with lower leaching potential, a meta model is used in order to derive the emission factors (Section 3.2.3). For the remaining substances, zero emission by drainage is assumed. The drainage emission factors are defined per unit of soil deposition rate and per unit area of crop treated. Appendix 4 contains the parent substances and metabolites with their drainage group number.

#### *Discharge from greenhouses (soilless cultivation)*

Emission factors for discharge from greenhouses with soilless cultivation were obtained from simulations of substance flow in the nutrient solution for three different scenarios (Section 3.2.5). For each national average application in a greenhouse crop with soilless cultivation, the resulting discharge events during a single growth cycle are stored in a database table (day number, volume of water and amount of substance). The water volume is expressed in m<sup>3</sup> and the substance amount in kg; both per unit greenhouse crop area. The percentile of the calculated exposure in the population of Dutch greenhouses is not known.

#### *Greenhouses (soil bound crops) and point source emissions*

Emission factors for soil bound greenhouse crops are based on an inventory at the end of the evaluation period of the 1<sup>st</sup> policy document (Liefstijl et al., 2000). Some emission factors are available for vapour pressure classes of the substance applied and for a few application techniques; whereas other emission factors are defined as a constant. These emission factors describe a kind of worst case scenario. The same applies to the emission factors for run-off from farm yards, for discharge from storage buildings for flower bulbs, and for the emission by discharge from mushroom cultivation (Sections 3.2.4 and 3.2.5).

## **2.4 Substance data**

Substance data in the NMI 3 are based on data recorded by Ctgb (further referred to as Ctgbase) and water quality standards obtained from the Helpdesk Water website ([www.helpdeskwater.nl](http://www.helpdeskwater.nl)), downloaded in November 2010). The latter data are used for the evaluation of the Dutch policy on sustainable agriculture, instead of the ecotox data present in Ctgbase. The following text presents a summary of the data and Appendix 4 gives a full list of the substance properties and the units used. A more detailed description of the substance properties is given in Van der Linden et al. (2012, in preparation).

Ctgbase contains data on physico-chemical, fate and ecotox parameters of plant protection products (PPP) and their metabolites. Sources of the Ctgbase are EU and Dutch authorisation dossiers. The data in the database are endpoints of individual experiments, some additional information on the experimental conditions and an indication of the reliability of the result. The reliability index is used to decide whether an individual value is included in further analyses.

#### *Reliability index (Quality index)*

In general, for each individual study or endpoint within a study, an indication is given on the reliability of the parameter value. Following categories are used:

1. reliable (study well performed and under optimal conditions)
2. less reliable (result may be influenced by suboptimal conditions, information might be lacking, ...)
3. not reliable (conditions outside acceptable ranges, unacceptable pre-incubation, misinterpretation without information for re-interpretation, ...)
4. assumed reliable, but information to check is missing
5. accepted for INS, i.e. accepted for setting environmental risk limits
6. rejected for INS, i.e. rejected for setting environmental risk limits
7. accepted for EU/Ctgb authorisation
8. rejected for EU/Ctgb authorisation

For EDG the following reliability indices were included: 1, 2, 4, 5, 7.

The assignment of a reliability index is based on Mensink et al. (2008) if the evaluation of the study took place in the Netherlands. Acceptability for EU authorisation is not based on such a manual. For the evaluation of the Dutch policy on sustainable agriculture the following reliability indices were included: 1, 2, 4, 5 and 7. This means that also less reliable data have been used in the calculations. Leaving out these data would result in quite a number of missing values for fate parameters and thus to a situation that the substances could not be included in the evaluation. Less reliable (index 2) for fate parameters usually indicates that the value is a upper limit in the case of half-life or a lower limit in the case of a sorption constant. Emissions and exposure concentrations estimated with such values will be upper limits. In authorisation procedures this would lead to conservative estimates. In trend analyses, emissions and concentrations will be upper limits in all the years and therefore the effect on the trend will be limited.

### *Parameters*

The NMI usually uses the common names of substances and a unique NMI ID number. In some cases, the common name is slightly modified in order to avoid problems in post-processing data. In addition, the CAS registration number is used for further identification in post-processing.

Physical and chemical properties include molar mass, saturated vapour pressure, (also referred to as P or P<sub>vap</sub>), acid dissociation constant (pK<sub>a</sub>) for weak acidic substances with a pK<sub>a</sub>-value between 2 and 8, water solubility, and the octanol water partitioning coefficient (K<sub>ow</sub>). The latter parameter is used to calculate the transpiration stream concentration factor, a parameter in the calculation of crop uptake of PPP. The NMI substance database contains only values for reference conditions. When applicable, original values are converted to reference conditions using following constants:

- A molar enthalpy of vaporisation equal to 95 kJ mol<sup>-1</sup>
- A molar enthalpy of dissolution equal to 27 kJ mol<sup>-1</sup>

Water solubility for dissociating substances was calculated for a pH-value of 7.

Substance fate parameters concern the sorption constant K<sub>om</sub> and the half-life in soil, water and water-sediment systems. In the database the half-lives are referred to as DegT50<sub>soil</sub>, DegT50<sub>water/sediment,water</sub> and DegT50<sub>water/sediment,system</sub>. The DegT50<sub>water/sediment,water</sub> is denoted here with DegT50<sub>water</sub> (Appendix 4, Table 4). If no values were available for the DegT50<sub>water</sub> then the half-life for hydrolysis in water was taken, if available. If the half-life in water and the half-life in water-sediment systems was missing, then the DegT50<sub>soil</sub> was taken as a substitute. For non-dissociating substances the average K<sub>om</sub>-value of individual data was calculated, when applicable after conversion. The conversion factor between organic matter and organic carbon was taken to be 1.724. For dissociating substances with pK<sub>a</sub>-values between 2 and 8, the K<sub>om,acid</sub> and K<sub>om,base</sub> were taken if available and otherwise, the maximum recorded value was taken as K<sub>om,acid</sub> and the minimum recorded value as K<sub>om,base</sub>. For half-lives, the geometric mean of standardized DegT50 values was calculated. For soil systems, standardization to 20 °C and pF=2 took place if temperature and / or moisture conditions were deviating; for other systems standardization to 20 °C. The activation energy was 54 kJ mol<sup>-1</sup> for soil studies and 75 kJ mol<sup>-1</sup> for water and water/sediment studies (used for a few substances only). The latter value is taken from Deneer (2010); the value per se is not very reliable as it is based on only a few measurements and was obtained for hydrolysis studies. The value of 54 kJ mol<sup>-1</sup> for soil studies is not according to the latest default value of 65.4 kJ mol<sup>-1</sup> (EFSA, 2007). The reason for this is that 1) the NMI meta model on leaching is based on results with the old default value of 54 kJ mol<sup>-1</sup>, and, 2) for a number of cases in the database standardised data are stated and not the original study data. Given the rather recent change in the default value of the activation energy, most of these conversions will have been done with the old default value. It was decided not to use half-lives from field experiments as it was generally unknown from the data whether standardization took place and, if so, whether it was performed according to acceptable

methodology. In the authorisation procedure values obtained from field experiments are used, so the values used in the NMI 3 for the evaluation of the Dutch policy plan may differ from the values used in the authorisation. In the calculations with the NMI 3, all temperature dependent calculations were performed using an activation energy of 54 kJ mol<sup>-1</sup>, so there is a mismatch for a few substances in the calculations for the surface water compartment.

The NMI takes metabolites into account, in the leaching and drainage modules and in the module for exposure in soil. The Ctgbase contains data on the maximum fraction found in an experiment (only soil data used here). The maximum fraction is a poor approximation of the formation fraction, which preferably should be used in calculations. Such data are however not available in the Ctgbase. The maximum formation percentage is used in want of better data. Metabolites for which fate parameters were not available were not included in the calculations.

#### *Ecotox parameters*

For the surface water compartment, the water quality standards (ad hoc) MTR are generally used. These values were obtained from the help desk water. If a (ad hoc) MTR was missing, it was tried to derive an equivalent value based on the procedure given in (Van Vlaardingen and Verbruggen, 2007), based on data available in Ctgbase. Ctgbase contains acute (e.g. EC50) and chronic ecotox (e.g. NOEC) values for many species in various compartments. In general, the geometric mean value is calculated if more than one value is available for a species in a compartment. Further data handling is described in Van der Linden et al. (2012, in preparation). The Ctgbase contains ecotox values for the acute situation. The data are recorded as EC50 or LC50 for algae, crustaceans, fish and water plants, usually EC50 and LC50 are recorded in mg L<sup>-1</sup>. In some dossiers, the value for algae is reported as a NOEC.

Ecotox data for metabolites are not always available. When necessary, data of parent substances are used. Missing values in the substance database are replaced by the median value of the data available. The substance database NMI 3 contains 288 parents and 33 metabolites.

## 3 Emission indicators

Although emission to soil is not considered as a separate emission indicator, net soil deposition is calculated as part of the calculations of drainage flow emissions and soil indicators and terrestrial risk indicators. For this reason this Chapter starts with a section on the calculation of net soil deposition. This calculation is performed in each plot contributing to the national crop area.

All emission indicators are calculated per unit of agricultural land. The emission indicators for atmospheric deposition, spray drift and drainage, and for greenhouse crops with soil bound cultivation are calculated for each plot contributing to the national area of the crop treated. The emission indicators for point source emissions and for emissions from greenhouses with soilless cultivation are independent of spatial information.

### 3.1 Crop interception, volatilisation and net soil deposition

The calculation of crop interception, soil deposition and volatilisation from soil was not changed from the previous version model (NMI 2). For this reason the description of these calculations is taken directly from (Van der Linden et al., 2008a).

Volatilisation during application was studied by Holterman (2000):

$$E_{air,app} = f_{al} A \quad \text{Equation 1}$$

$E_{air,app}$  emission to air during application, (kg ha<sup>-1</sup>)  
 $f_{al}$  fraction of the dose lost during application, (-), default 0.03  
 $A$  the nominal rate for a single application, (kg ha<sup>-1</sup>)

The result was included in the NMI; for a typical spray application on arable fields 3% of the applied amount stays in the air for a longer period and can be transported to outside the treated area. A part of the spray-droplets is or becomes so small that they stay air-borne and their residence in the air is prolonged. The fraction volatilised during spraying when using an axial sprayer, as for instance in fruit cultivation and tree nurseries, might be higher. Data to support this assumption are lacking.

Whenever a plant protection product is sprayed over a crop, part of the dose may be intercepted by the crop. The percentage intercepted is dependent on the growth stage of the crop and the application technique. Appendix 5 gives a table with the crop interception fractions, and a table with the extrapolation to crops not covered by the original data. These crop interception data were taken from the NMI 2.

Initial soil deposition is calculated as the application rate minus the volatilisation during application minus the fraction of the application rate intercepted by the crop:

$$S_{init} = A (1 - f_{al}) (1 - f_{int}) \quad \text{Equation 2}$$

$S_{init}$  the initial soil deposition (kg ha<sup>-1</sup>)  
 $f_{int}$  the crop interception fraction (-)

Part of the material initially deposited on the soil may evaporate, resulting in a decrease of the amount deposited onto the soil. Volatilisation from the soil surface is calculated using a regression equation (Smit et al., 1997; Smidt et al., 2000):

$$CV_{soil} = 71.9 + 11.6 \cdot 10^{\log(100 FP_{gas})} \quad \text{Equation 3}$$

$CV_{soil}$  the cumulative volatilisation from the soil surface (% of amount reaching the soil).  
 $FP_{gas}$  the fraction of the substance in the gas phase (%)

The net soil deposition,  $S_N$ , needed in the calculation of drainage flow emissions and soil and terrestrial risk indicators is given by:

$$S_N = S_{init} \left(1 - \frac{CV_{soil}}{100}\right) \quad \text{Equation 4}$$

$S_N$  the net soil deposition (kg ha<sup>-1</sup>)  
 $S_{init}$  the initial soil deposition (kg ha<sup>-1</sup>)  
 $CV_{soil}$  the cumulative volatilisation from the soil surface (% of amount reaching the soil).

The calculation of  $CV_{soil}$  uses the fraction of substance in the gas phase ( $FP_{gas}$ ) as a starting point:

$$FP_{gas} = \frac{\varepsilon_{gas}}{\left(\varepsilon_{gas} + \varepsilon_{liquid} K_{lg} + \rho K_{lg} K_{sl}\right)} \quad \text{Equation 5}$$

$FP_{gas}$  the fraction of substance in the gas phase, (-),  $0 \leq FP_{gas} \leq 1$   
 $\varepsilon_{gas}$  the volumetric gas fraction, (volume gas per volume soil, dm<sup>3</sup> dm<sup>-3</sup>)  
 $\varepsilon_{liquid}$  the volumetric liquid fraction, (volume soil solution per volume soil, dm<sup>3</sup> dm<sup>-3</sup>)  
 $\rho_{soil}$  the soil dry bulk density, (kg dm<sup>-3</sup>)  
 $K_{lg}$  the liquid to gas partitioning coefficient, (dm<sup>3</sup> dm<sup>-3</sup>)  
 $K_{sl}$  the soil to liquid partitioning coefficient, (dm<sup>3</sup> kg<sup>-1</sup>), (see Equation 13)

The volumetric gas fraction is calculated according to:

$$\varepsilon_{gas} = 1 - \varepsilon_{liquid} - \varepsilon_{solid} \quad \text{Equation 6}$$

$$\varepsilon_{solid} = \frac{\rho}{\rho_{solid}} \quad \text{Equation 7}$$

$$\rho_{solid} = \frac{1}{\frac{f_{om}}{\rho_{om}} + \frac{(1-f_{om})}{\rho_{min}}} \quad \text{Equation 8}$$

$\epsilon_{\text{solid}}$	volumetric solid fraction (volume solid parts per volume soil)
$\rho$	soil dry bulk density (kg dm <sup>-3</sup> )
$\rho_{\text{solid}}$	density of the solid phase (kg dm <sup>-3</sup> );
$\rho_{\text{om}}$	density of organic matter (= 1.47 kg dm <sup>-3</sup> )
$\rho_{\text{min}}$	density of mineral parts (= 2.66 kg dm <sup>-3</sup> )

Some records in the database describe multiple applications. Such a record refers only to a single date of application (at the mid of the application month), but the application events will be distributed over time in a symmetric fashion around the application time given, taking into account the number of application events and the interval between application events. An example is given in Table 6.

**Table 6**

*Application event dates at four applications with application date March 15 (7-days application interval, and different number of application events). This application date corresponds with Julian day number 74.*

Number of application events	Application event day			
	1	2	3	4
1	74			
2	71	78		
3	67	74	81	
4	64	71	78	85

Because temperature is available on a daily basis, this pattern influences the liquid to gas partition coefficient,  $K_{lg}$  (see the equations for temperature correction of substance properties below at this section).

Dissociation of substances also influences the partitioning of the substance over the three phases in the soil. For weak acidic plant protection products Equation 5 is modified to account for the dissociation of the substance.

$$FP_{\text{gas}} = \frac{\epsilon_{\text{gas}}}{\left( \epsilon_{\text{gas}} + \frac{\epsilon_{\text{liquid}} K_{lg} + \rho K_{lg} K_{sl}}{f_{ND,soil}} \right)} \quad \text{Equation 9}$$

with

$\epsilon_{\text{gas}}$	volumetric gas fraction (volume gas per volume soil, dm <sup>3</sup> dm <sup>-3</sup> )
$\epsilon_{\text{liquid}}$	volumetric liquid fraction (volume soil solution per volume soil, dm <sup>3</sup> dm <sup>-3</sup> )
$\rho$	soil dry bulk density (upper 0.05 m; in kg dm <sup>-3</sup> )
$K_{lg}$	liquid to gas partitioning coefficient (dm <sup>3</sup> dm <sup>-3</sup> )
$K_{sl}$	soil to liquid partitioning coefficient (dm <sup>3</sup> kg <sup>-1</sup> )
$f_{ND,crop}$	fraction of substance at the soil surface in non-dissociated form (-)

Equation 9 is a modification assuming that an ion has a saturated vapour pressure equal to zero.

$$f_{ND,soil} = \frac{1}{1 + 10^{(pH - pK_a)}} \quad \text{Equation 10}$$

pH the soil pH at the plot (upper 0.05 m; -)  
 pK<sub>a</sub> dissociation constant of the substance (-)

The partitioning of the substance over the solid phase and the liquid phase is expressed by the partitioning coefficient K<sub>sl</sub>, according to:

$$K_{sl} = om_5 K_{om} \quad \text{Equation 11}$$

and, for substances with pH-dependent sorption behaviour:

$$K_{sl} = om_5 K_{om,com} \quad \text{Equation 12}$$

with

om<sub>5</sub> the local organic matter fraction in the topsoil (upper 5 cm), (kg kg<sup>-1</sup>)  
 K<sub>om</sub> the organic matter sorption constant, (dm<sup>3</sup> kg<sup>-1</sup>)  
 K<sub>om,com</sub> the combined sorption constant, (dm<sup>3</sup> kg<sup>-1</sup>), see Equation 40.

#### Temperature correction

The liquid to gas partitioning coefficient, K<sub>lg</sub>, is the inverse of the dimensionless Henry coefficient, K<sub>H</sub> (-):

$$K_{lg} = \frac{1}{K_H} \quad \text{Equation 13}$$

K<sub>lg</sub> liquid to gas partitioning coefficient (-)  
 K<sub>H</sub> dimensionless Henry coefficient, taken from Adriaanse (1996) (-)

$$K_H = \frac{0.001 P_{sat} MM}{R T S} \quad \text{Equation 14}$$

P<sub>sat</sub> saturated vapour pressure (mPa)  
 MM molar mass, (g mol<sup>-1</sup>)  
 R molar gas constant, (8.314 J mol<sup>-1</sup> K<sup>-1</sup>)  
 T temperature at the time and place of the application, (K)  
 S solubility in water, (mg dm<sup>-3</sup>)  
 0.001 conversion factor from mPa to Pa

The Henry coefficient is dependent on the temperature as both the saturated vapour pressure and the water solubility are dependent on temperature:

$$P_{sat} = \frac{P_{sat,ref}}{f_T} \quad \text{Equation 15}$$

$$f_T = \exp\left(\frac{-E_{vol}}{R} \left(\frac{1}{T_{ref}} - \frac{1}{T}\right)\right) \quad \text{Equation 16}$$

$P_{sat}$	saturated vapour pressure (mPa)
$P_{sat,ref}$	saturated vapour pressure of the substance at reference temperature (mPa)
$f_T$	temperature correction factor (-)
$E_{vol}$	molar enthalpy of volatilisation (J mol <sup>-1</sup> ) (95000 J mol <sup>-1</sup> )
$R$	molar gas constant (J mol <sup>-1</sup> K <sup>-1</sup> ) (value 8.314 J mol <sup>-1</sup> K <sup>-1</sup> )
$T_{ref}$	reference temperature (K), (value 293.15 K ≡ 20 °C)
$T$	temperature at the time and place of the application event (K)

$$S = \frac{S_{ref}}{f_T} \quad \text{Equation 17}$$

$$f_T = \exp\left(\frac{-E_{dis}}{R} \left(\frac{1}{T_{ref}} - \frac{1}{T}\right)\right) \quad \text{Equation 18}$$

$S$	solubility in water (mg L <sup>-1</sup> )
$S_{ref}$	solubility in water of the substance at reference temperature (mg L <sup>-1</sup> )
$f_T$	temperature correction factor (-)
$E_{dis}$	molar enthalpy of dissolution (J mol <sup>-1</sup> ), (27000 J mol <sup>-1</sup> )
$R$	molar gas constant (J mol <sup>-1</sup> K <sup>-1</sup> ), (value 8.314 J mol <sup>-1</sup> K <sup>-1</sup> )
$T_{ref}$	reference temperature (K), (value 293.15 K ≡ 20 °C)
$T$	temperature at the time and place of the application event, (K)

The average daily temperature is available for fourteen meteorological regions, and each plot is assigned to one of these meteorological regions.

## 3.2 Surface water

Emission indicators to surface water represent the load to surface water in a watercourse adjacent to the agricultural field, farm yard or greenhouse. The NMI 3 includes modules for calculating emission to surface water resulting from atmospheric deposition, spray drift, drainage flow, point sources, and discharge from greenhouses. These modules are described in next sections.

### 3.2.1 Atmospheric deposition

Atmospheric deposition may occur during a relatively short period (hours) starting at the application event. Although the dependency of atmospheric deposition is less strong than in case of spray drift, the information on different crop free zones and the distance from the crop edge to the water body is used in a similar way in both models. The indicator for atmospheric deposition accounts for the downwind deposition of vaporized PPP, onto the water surface in the field ditch. The atmospheric deposition fraction at distance  $x$  from the crop edge is calculated according to the model EVA 2.0:

$$y = p \cdot e^{q \cdot (x-1)} \quad \text{Equation 19}$$

$p$	parameter for saturated vapour pressure class <i>high</i> , <i>medium</i> and <i>low</i> (Table 7)
$q$	= -0.05446



- x the distance to the crop edge (m),
- y the cumulative fraction of the dosage deposited during the first 24 h after application, defined as mass of PPP per unit surface area of water divided by mass of PPP per unit surface area of agricultural land (kg ha<sup>-1</sup>) / (kg ha<sup>-1</sup>)

The distance x is taken from the crop edge (at position 0; Figure 13). FOCUS, 2008 gives slightly different vapour pressure classes for soil applications and for crop applications. Since the majority of spraying applications in the NMI database are crop applications, it was decided to use the vapour pressure classes for crop applications to all spraying applications. According to (FOCUS, 2008) expert consultation is required for estimating the atmospheric deposition function for substances in vapour pressure class 5. In the NMI 3 these substances are assigned to vapour pressure class 4, with the atmospheric deposition curve class *high*.

**Table 7**

Saturated vapour pressure classes for crop applications (according to FOCUS, 2008, with function parameter p divided by 100 in order to obtain the deposition fraction instead of percentage).

Vapour pressure class nr.	Range of vapour pressure (Pa)	Class name (Figure 6)	P (Equation 19)
1	< 10 <sup>-5</sup>	-	0
2	10 <sup>-5</sup> ≤ vp < 10 <sup>-4</sup>	low	0.00089
3	10 <sup>-4</sup> ≤ vp < 5 · 10 <sup>-3</sup>	medium	0.00221
4	5 · 10 <sup>-3</sup> ≤ vp < 10 <sup>-2</sup>	high	0.01555
5	vp ≥ 10 <sup>-2</sup>		

**Figure 5.4–1: Comparison of deposition caused by spray drift (FOCUS SW, arable crops, instantaneous event) and by volatilisation from arable crops (as predicted by EVA 2.0, cumulative over 24 h)**

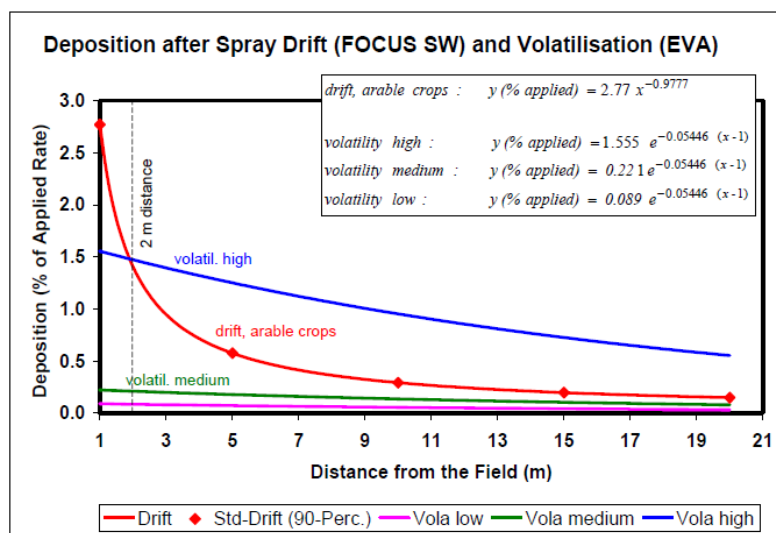

**Figure 6**

Copy of Figure 5.4-1 of (FOCUS, 2008) showing the atmospheric deposition percentage as a function of the distance to the field. In the NMI 3 the distance is taken from the crop edge (at position 0; Figure 13).

The average atmospheric deposition for two points B en C, located at distance OB and OC from the origin (Figure 13), is approximated by the geometric mean of the deposition at both distances:

$$y_{OB} = p \cdot e^{q(OB-1)}$$

$$y_{OC} = p \cdot e^{q(OC-1)}$$

$$\bar{y} = \sqrt{y_{OB} y_{OC}}$$

**Equation 20**

With:

OB the distance between the crop edge and the 1<sup>st</sup> surface water boundary (m)

OC the distance between the crop edge and the 2<sup>nd</sup> surface water boundary (m)

p, q function parameters (Equation 19)

$\bar{y}$  the average deposition fraction between two points at distance OB and OC (kg ha<sup>-1</sup>) / (kg ha<sup>-1</sup>)

The deposition fraction over the full width of the water surface is obtained by multiplying the average deposition fraction by the width of the water surface. The calculation has to account for the possible presence of different crop free zones, each of them differing in the distance OB to the water surface. Moreover, the existence of three different water classes with different widths has to be taken into account.

For each combination of crop free zone j and water class s, the deposition percentage over the full width of each of the surface water classes is given by:

$$Y_{j,s} = \bar{y}_{j,s} (OC_{j,s} - OB_{j,s})$$

**Equation 21**

With:

$Y_{j,s}$  the deposition fraction times the full width of the water body (m)

$\bar{y}_{j,s}$  the average deposition fraction between two points at distance  $OB_{j,s}$  and  $OC_{j,s}$  (kg ha<sup>-1</sup>) / (kg ha<sup>-1</sup>)

$OB_{j,s}$  the distance between the crop edge and the 1<sup>st</sup> surface water boundary for crop free zone j and watercourse class s (m)

$OC_{j,s}$  the distance between the crop edge and the 2<sup>nd</sup> surface water boundary for crop free zone j and watercourse class s (m)

For each of the surface water classes the average deposition fraction is calculated by accounting for the abundance (degree of implementation, IG) of each of the various crop free zones:

$$Y_{ad} = \sum_{j=1}^n (IG_j Y_j)$$

**Equation 22**

With:

$Y_{ad}$  the average deposition fraction times the full width of the water body (m)

$IG_j$  implementation degree for a crop free zone ( $0 \leq IG_j \leq 1$  and  $\sum (IG_j) = 1$  (-))

$Y_j$  the deposition fraction times the full width of the water body (m)

j index for the crop free zone

The implementation degree IG is a weighting factor for spraying equipment (sprayer, nozzle), emission reducing measures and crop free zone. Equation 22 is used to calculate the deposition fraction  $Y_{ad}$  for each watercourse class. The emission per ha agricultural land for atmospheric deposition is calculated according to;

$$E_{sw,ad} = A \left( \sum_{s=1}^{n=3} Y_{ad,s} L_s \right)^{1/2} \cdot 10^{-4}$$

**Equation 23**

$E_{sw,ad}$	emission to field ditches by atmospheric deposition (kg ha <sup>-1</sup> )
A	application rate (kg ha <sup>-1</sup> )
$L_s$	length of field ditches per unit area of agricultural land in the plot, watercourse class s (m ha <sup>-1</sup> )
$Y_{ad,s}$	the average deposition fraction times the full width of the water body, watercourse class s (m)
$1/2$	wind direction factor (-)
$10^4$	conversion of dosage from kg ha <sup>-1</sup> to kg m <sup>2</sup> (ha m <sup>2</sup> )
n	the number of watercourse classes (= 3)

The atmospheric deposition fraction  $Y_{ad}$  is multiplied with the length of the corresponding watercourse class. It is assumed that only the water surface area at the downwind side of the field can receive air borne and spray drift deposits; therefore the factor  $1/2$  is included in Equation 23. These watercourses are represented by Group C in Figure 5.

### 3.2.2 Spray drift

#### *Differentiation of crop types for spray application*

In the authorization procedure for plant protection products (PPP) in the Netherlands a differentiation is made in the spray drift amount originating from spray applications in arable crops (including field vegetables, flowers, small fruits and small tree nursery crops, weed control in fruit and nursery tree crops), fruit crops and tree nursery crops. Basis for this differentiation is the way PPPs are applied. In arable crops (including small nursery tree crops) a field boom sprayer is used with a downward spray direction. In fruit trees and nursery trees an upward or sideward directed spray technique is used. Based on the crop growth situations and the used spray techniques, different spray drift deposition curves are used to determine the exposure to surface water. These curves are approximately a 90<sup>th</sup> temporal percentile for downward directed spraying techniques and approximately a 70<sup>th</sup> temporal percentile for upward spraying techniques, considering only ditches that are downwind of treated fields (Van der Zande et al., 2012).

Crops sprayed with downward directed spray techniques can be further distinguished in intensively sprayed crops, cereals and other crops (Figure 7). This differentiation is based on the minimally required crop-free buffer zone based on agricultural practices (harvest, mechanization and tyre width). The minimal crop-free buffer zones are 0.25 m for cereal crops and grassland, 0.50 m for crops like sugar beet, maize, beans, etc. and 0.75 m for potatoes, flower bulbs, strawberries (referred to as intensively sprayed crops in the Dutch regulation LOTV).

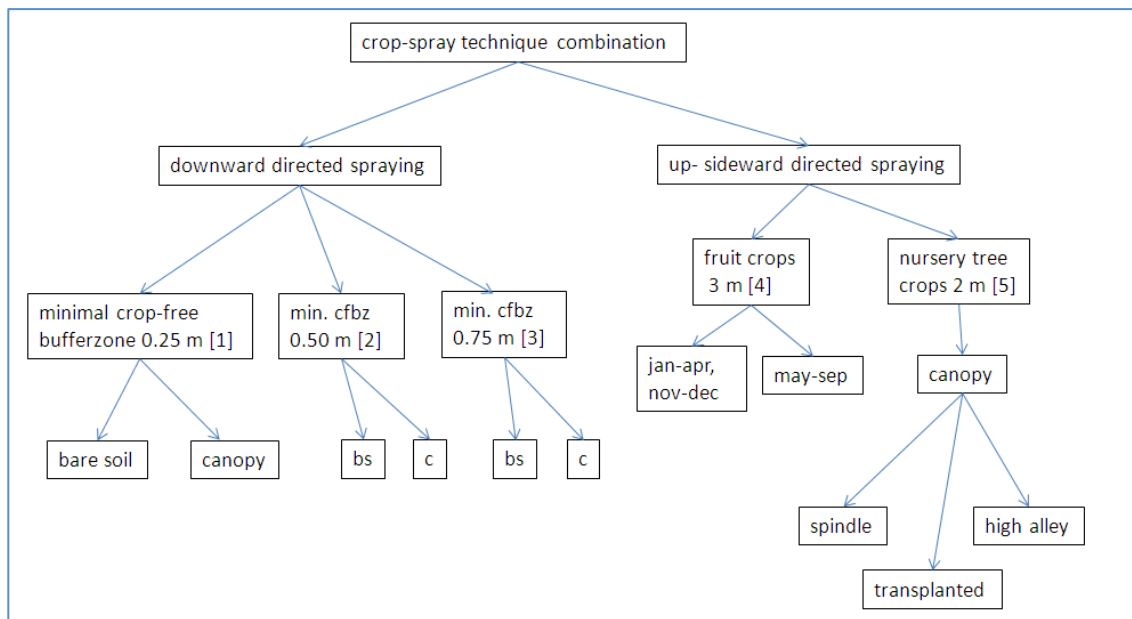

**Figure 7**

*Differentiation of the assessment of spray drift to crop types and growth situations with minimal width of crop-free buffer zones based on agronomic requirements. In the Figure cfbz means crop free buffer zone, bs means bare soil and c means canopy.*

An overview of the different treatments and crops where these treatments are applied is given in Appendix 6, with reference to the index numbers between square brackets in boxes of Figure 7. Note that downward directed spraying may occur in fruit crops and nursery tree crops as well, i.e. in case of herbicide application.

### *Spray drift*

Since 1988 field measurements of spray drift have been performed and data are incorporated in a drift database (Zande et al., 2012). Drift measurements have been done in spraying arable crops like potatoes and bare soil surface, fruit crops (apples) in the full leaf and dormant situation and nursery trees of different sizes. The background of the measurements was to determine the drift from generally used application techniques, defined as a reference situation, and to determine the effect of drift reducing technology in comparative measurements with these identified reference application techniques. Data derived from measurements in the period 1988-2005 were used to generate spray drift curves for the reference application techniques and to determine drift reduction curves for drift reducing technology. The drift database contains a large range of application techniques:

- conventional boom sprayer;
- air assistance on a boom sprayer;
- nozzle types of the classes 50%, 75% and 90% reduction;
- end nozzle use to prevent overspray at the field edge;
- low boom height with two nozzle types;
- low boom height with two nozzle types and additional air assistance;
- Släpduk system with two nozzle types;
- air assistance system (Hardi Twin Force) with two nozzle types;
- band sprayer in sugar beet and maize;
- shielded spray boom with two nozzle types;
- barrier vegetation of different heights;
- tunnel sprayer for bed-grown crops when spraying an arable crop, a flower bulb crop or a flower, ornamental or small fruit crop.

For orchard spraying the reference spray technique is a cross-flow fan sprayer. The experiments were carried out in early (dormant) and late growth stages (full canopy) of the apple trees. In the early growth stages (developing foliage), air assistance is supplied with low gear settings of the fan. In the fully developed foliage stage, experiments are carried out with high gear fan settings. The following application techniques are included in the drift database:

- Conventional cross-flow fan sprayer;
- Single sided spraying of the outside tree row;
- Tunnel sprayer;
- Sensor equipped spraying - gap detection;
- Sprayer with reflection shields;
- Sprayer with reflection shields and drift reducing nozzle types;
- Coarse droplet application;
- Windbreaks at the field edge;
- Riparian vegetation;
- Artificial netting at the field edge.

In high nursery (alley) trees, an axial fan sprayer equipped with TeeJet TXB03 hollow cone nozzles operating at 10 bar spray pressure was used as reference technique. Spray drift measurements were performed in the full leaf stage of the trees.

Generic spray drift curves were derived by regression analysis from the field experiments. Figure 8 shows these drift curves for reference spray techniques and techniques corresponding to the drift reduction classes 50, 75, 90 and 95%, for field crops. Similarly, Figure 9 shows generic drift curves for treatments at bare soil.

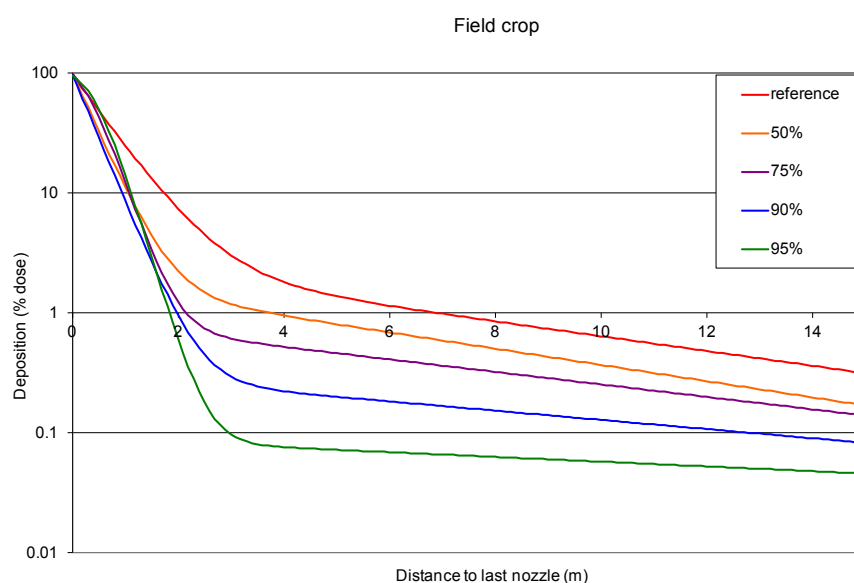

**Figure 8**

*Spray drift deposition curves of the standard and 50%, 75%, 90% and 95% drift reducing technology spray techniques for downward directed spray applications (boom sprayer) for field crops.*

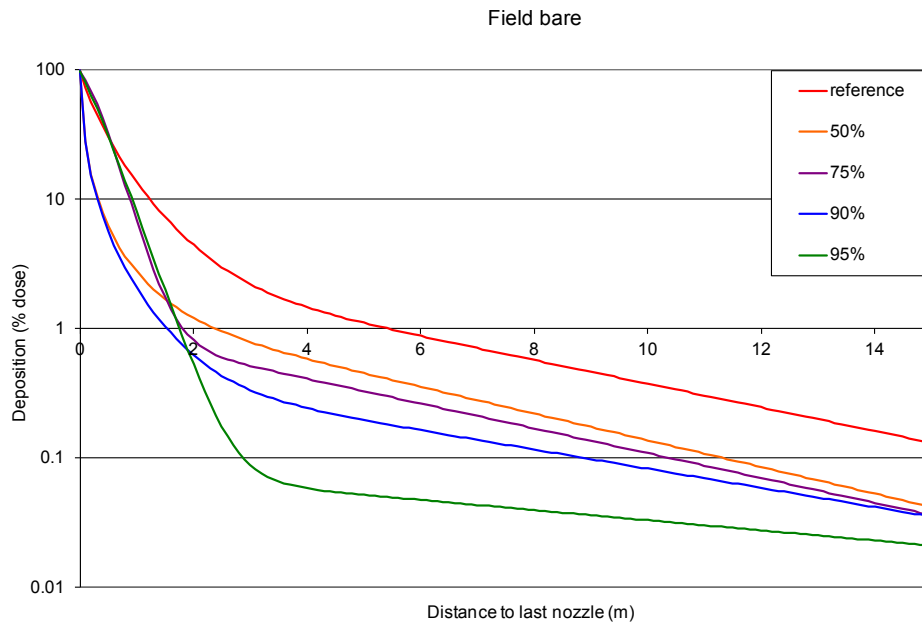

**Figure 9**

*Spray drift deposition curves of the standard and 50%, 75%, 90% and 95% drift reducing technology spray techniques for downward directed spray applications (boom sprayer) in a bare soil - small crop situation .*

For fruit crops, a distinction between full leaf stage and dormant stage is made. The corresponding generic drift curves are shown in Figure 10 and Figure 11, respectively. Due to the one-sided spraying of the outside row for the DRT90 application technique the spray drift deposition curve declines steeper than the other curves.

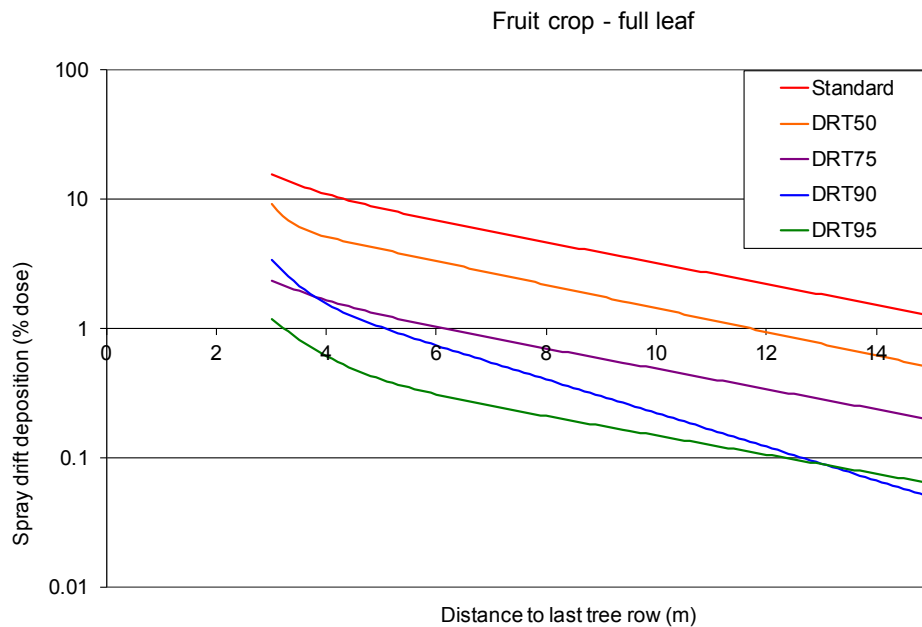

**Figure 10**

*Spray drift deposition curves for the reference and typical 50%, 75%, 90% and 95% drift reduction classes application techniques in orchard spraying (full leaf situation).*

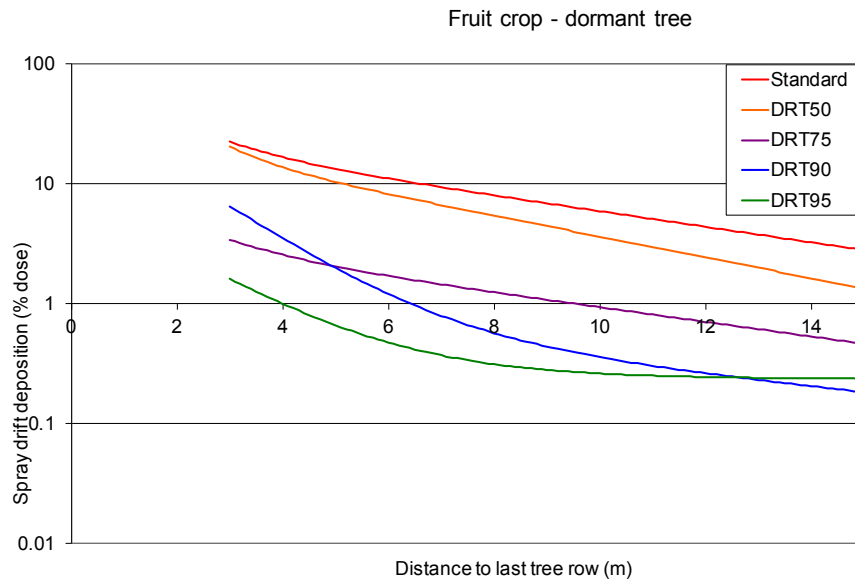

**Figure 11**  
 Spray drift deposition curves for the reference and typical 50%, 75%, 90% and 95% drift reduction classes application techniques in orchard spraying (dormant situation).

The spray drift deposition curves next to the tree nursery for the standard spray technique in the nursery tree situations spindle and transplanted tree are presented in Figure 12. In the NMI only the transplanted tree spray drift curve is used.

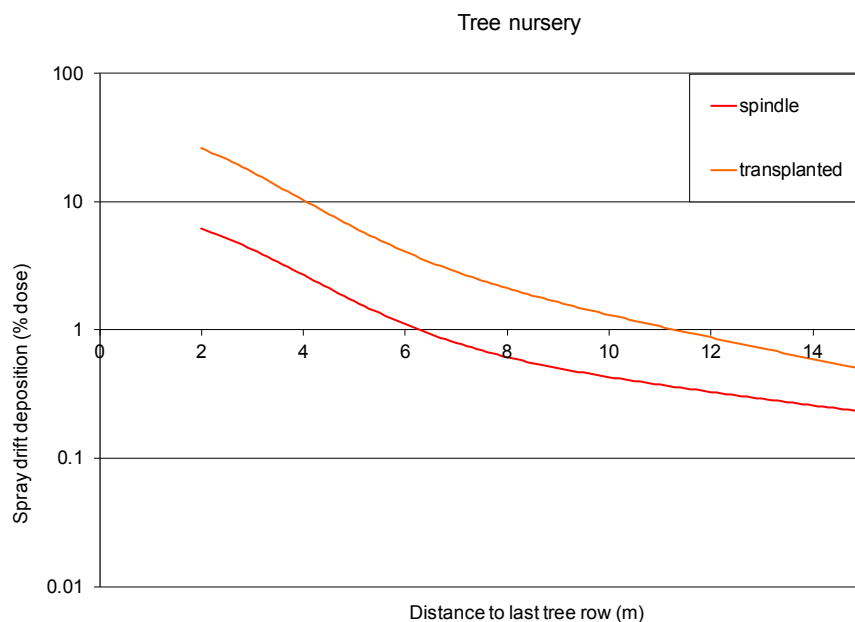

**Figure 12**  
 Standard spray drift deposition curves for the standard axial-fan spray techniques used in spindle and transplanted nursery trees.

### Starting point of the spray drift curve

The placement of the last nozzle defines the starting point of the drift curve. For each of the crop groups, a differentiation can be made in the position of the last nozzle on the spray boom in relation to the last crop row (O in Figure 13). Last nozzle to row distances for the different crop types are typically 12.5 cm outside of the last crop row, on top of the last crop row, 25 cm inside of the last crop row and 50 cm inside the last crop row/outside edge of the crop. This means that the spray drift calculations for the different crops can be limited to nine specific crop groups.

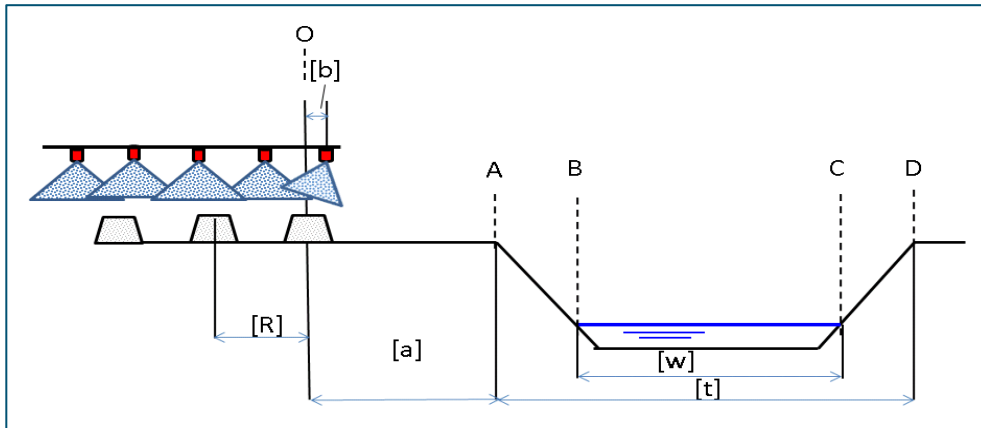

**Figure 13**

Scheme to identify the relevant distances in spray applications for field situations: [a] crop-free buffer zone, distance between top of ditch bank and center of first plant row (OA), [b] distance between last nozzle position and last crop row, [R] row distance between crop rows [w] width at water surface (BC), [t] width top of ditch, between top of banks (AD).

### Computing average spray drift on water body surfaces

The NMI Drift Calculator (version 1.1, March 2010) used the generic drift curves described above to generate a dataset of spray drift deposits on water body surfaces. The spray drift deposition functions are defined with the origin ( $x = 0$ ) at the position of the outer nozzle. The following generic drift function was used to calculate drift deposition fractions for relevant combinations of crop type, sprayer, nozzle type, crop free zone, with the cross-sectional profiles in 22 regions and three watercourse classes;

$$y = \frac{a_0 e^{-a_1 x} + b_0 e^{-b_1 x}}{1 + c_0 e^{-b_1 x}} \quad \text{Equation 24}$$

With:

- y the drift percentage, defined as mass of PPP per unit surface area of water divided by mass of PPP per unit surface water of agricultural land ( $\text{kg ha}^{-1}$ ) / ( $\text{kg ha}^{-1}$ )
- x distance from the outmost nozzle
- $a_0$ ,  $a_1$ ,  $b_0$ ,  $b_1$  and  $c_0$  constants.

Drift deposits are given as a percentage of the applied dose (at a nominal rate =  $1 \text{ kg a.i. ha}^{-1}$ ) per unit surface area of water. The double exponential form of numerator describes well the general form of downwind drift deposit curves. The denominator acts as a correction factor for deposits close to the field edge.



To obtain the average drift deposits on the surface of a water body, the given function is integrated numerically over the surface width of the water body, using an integration step size of 0.005 m, and divided by the width.

Drift curves are available for different crops and different drift reduction classes and their parameters are derived from regression analysis by fitting experimental data. For field crops 5 drift curves are used: a representative curve for a conventional sprayer and curves for sprayers with drift reduction classes 50, 75, 90 and 95%. Similarly, five drift curves are used for representative sprayers for each of the following cases: spraying bare soil or short grass and spraying fruit trees in both the dormant and the full leaf stage of the wind shield. For nursery trees a distinction is made in two growing types (spindle trees and transplanted trees); only conventional spraying is defined in these cases. This gives a total of 22 different drift curves.

For field crops, the curves are combined with three crop classes (intensive, cereals, other), each of which has three subtypes defining the position of nozzles with respect to that of the last row of crop plants. Together with the cases for bare soil, fruit trees and nursery trees a total of 62 situations is obtained in which a generic crop type is combined with an appropriate generic spray application. Additionally, since the crop free buffer zones were redefined in the first part of the evaluation period, two distinct sets of 62 situations are defined representing the reference year 1998 and the years 2004 and 2008.

Finally, each of these situations is applied to the 66 standard profiles of water bodies, and average drift deposits in a cross wind is computed by numerical integration as described above. Drift deposit figures for the standard ditch used in current Dutch registration were added for reference. This has resulted in a dataset of 8308 drift deposit values for all possible generic situations ((2 x 62) x (66 + 1) = 124 different crop growth situations and spray techniques multiplied by 67 profiles). This dataset is available as an input file to the NMI3 model.

For each of the surface water classes the average drift percentage is calculated by accounting for the abundance (degree of implementation IG) of each of the crop free zones:

$$\bar{Y}_{sd} = \sum_{j=1}^n (IG_j \bar{Y}_j) \quad \text{Equation 25}$$

With:

$\bar{Y}_{sd}$  average spray drift percentage for the water surface area between two points at distance OB and OC (kg ha<sup>-1</sup>) / (kg ha<sup>-1</sup>)

$\bar{Y}_j$  spray drift percentage, at crop free zone j (kg ha<sup>-1</sup>) / (kg ha<sup>-1</sup>)

$IG_j$  implementation degree for a combination of application technique and crop free zone (0 ≤ IG<sub>j</sub> ≤ 1 and Σ (IG<sub>j</sub>) = 1 (-))

n the number of crop free zones

The emission per ha agricultural land for spray drift is calculated according to:

$$E_{sw,sd} = A \left( \sum_{s=1}^{n=3} 0.01 \bar{Y}_{sd,s} w_s L_s \right)^{1/2} \cdot 10^{-4} \quad \text{Equation 26}$$

With:

$E_{sw,sd}$  emission to field ditches by spray drift deposition (kg ha<sup>-1</sup>)

A application rate (kg ha<sup>-1</sup>)

$\bar{Y}_{sd,s}$  average spray drift percentage, watercourse class s (kg ha<sup>-1</sup>) / (kg ha<sup>-1</sup>)

$w_s$  width of the water surface, watercourse class s (distance BC) (m)

$L_s$	length of field ditches per unit area of agricultural land in the plot, watercourse class s (m ha <sup>-1</sup> )
$\frac{1}{2}$	wind direction factor (-)
$10^4$	conversion of dosage from kg ha <sup>-1</sup> to kg m <sup>-2</sup> (ha m <sup>-2</sup> )
n	the number of watercourse classes (= 3)

The average spray drift factor is multiplied with the width of the water body (BC in Figure 13) and with the length of the corresponding watercourse class. The factor 0.01 is needed for conversion from % into a fraction. It is assumed that only the water surface area at the downwind side of the field can receive air borne and spray drift deposits; therefore the factor  $\frac{1}{2}$  is included in Equation 26. These watercourses are represented by Group C in Figure 5.

### 3.2.3 Drainage flow

Emission by flow through cracks in heavy clay soils with pipe drainage is a relatively fast process. Discharge events during a rain storm may cause exposure concentrations in the field ditch exceeding the water quality standard (Figure 14). Discharge processes in soils with no pipe drainage and/or in sandy soils and peat soils, not characterised by these peak events, will generally lead to much lower exposure concentrations in the field ditch.

Discharge from heavy clay soils with pipe drainage depends on soil properties, soil hydrology and climate properties, so emission factors are needed for all relevant plots of the soil hydrological schematisation of the Netherlands. The indicator for drainage flow is based on a recently developed exposure scenario for aquatic organisms (Tiktak et al., 2012b). Two sets of drainage emission factors were derived for the NMI 3:

1. For a group of 48 critical substances, emission factors were obtained from simulations with the GeoPEARL model for macroporous flow.
2. For a group of less critical substances, emission factors were estimated using a meta model derived from GeoPEARL calculations.

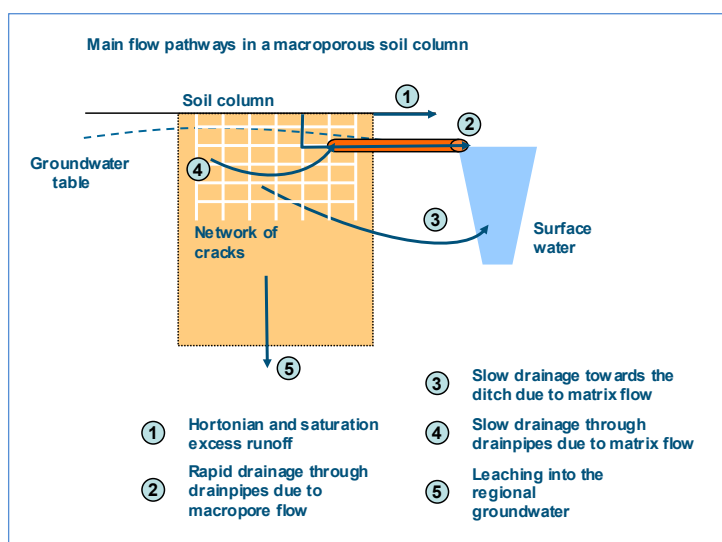

**Figure 14**

Main flow pathways in a typical Dutch macroporous soil with pipe drainage. The emission indicator for drainage represents the pathways (4), (2), (3) and (1). (copy of Figure 4 in Tiktak et al., 2012b).

The performance of the meta model in comparison with the GeoPEARL model simulations has not yet been investigated thoroughly.

For the remaining substances in the NMI database, zero drainage was assumed. The drainage group number of the substances in the NMI database is listed in Appendix 4. Both the simulation results and the meta model cover 4 application times and 5936 plots with an agricultural area. These application times in the GeoPEARL 4 model were translated to the application time in the NMI 3 (Table 8). All drainage emission factors used in the NMI 3 are 87.5<sup>th</sup> percentile annual loads (rank number 18, with n = 20), defined per unit of soil deposition and per unit of area treated (the aeric mass drained in kg a.i. ha<sup>-1</sup>).

**Table 8**

*The application time in the GeoPEARL model related to the application time in the usage data (month numbers; the 15<sup>th</sup> day of the month is used in both models).*

GeoPEARL	NMI 3
1	1
	2
	3
4	4
	5
6	6
	7
9	8
	9
	10
1	11
	12

*Emission factors based on model simulations*

The first group of substances in the NMI database was selected based on their importance in the results for the mid-term evaluation EDG-2006, i.e. based on the leaching potential of the substance, the environmental risk according to the water quality standard (Maximum Permissible Concentration/MPC), and the national sales volumes. The drainage factors were obtained from 20-years simulations with GeoPEARL 4. The field ditch model of the NMI 3 (Section 4.1.2, Equation 54) was connected to GeoPEARL for this purpose, in order to obtain both the daily drainage volume and substance load and the resulting concentration in the field ditch in one model run (exposure concentrations are discussed in Chapter 4). The daily output was converted to a series of annual loadings and exposure concentrations in the field ditch. The GeoPEARL model and the NMI 3 use the same values for the volume of water in the field ditch and the ditch dimensions. GeoPEARL was run with a single, annual application at the soil surface, resulting in a nominal soil deposition (1 kg ha<sup>-1</sup>). No tillage or ploughing was simulated.

Figure 15 shows an example of annual mass fraction drained and the annual maximum exposure concentrations in the field ditch. The NMI 3 uses the 87.5<sup>th</sup> percentiles (rank number 18).

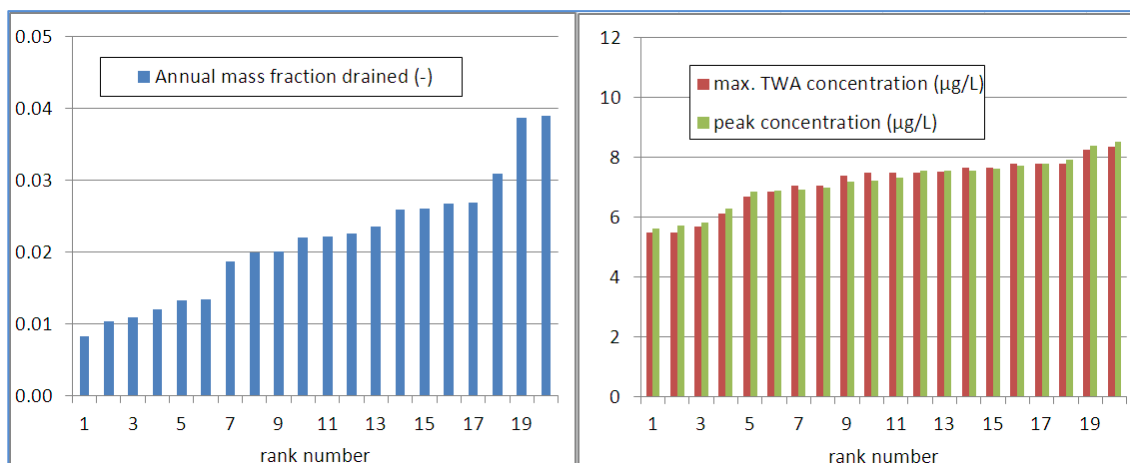

**Figure 15**

Example of the annual mass fractions drained (left) and annual exposure concentrations (right) in the field ditch (results for imidacloprid, application month 6 (June), reference plot 4550). The drainage module in the NMI 3 uses the 87.5<sup>th</sup> percentile (rank number 18) and exposure concentrations converted from ( $\mu\text{g L}^{-1}$ ) to  $\text{mg L}^{-1}$ . (GeoPEARL 4).

#### Emission factors based on the meta model

Because these simulations with GeoPEARL 4 require long grid computing times, only the most critical substances were included in the 1<sup>st</sup> group. For the 2<sup>nd</sup> group of less critical substances a meta model was built based on the results for the first group and on additional simulation results for a reference plot. This reference plot 4550 was chosen based on the leaching risk which approximates the 80<sup>th</sup> percentile risk of leaching towards the groundwater.

The GeoPEARL 4 model was used to calculate the emission factor and the ditch concentrations for the reference plot 4550 for all substances in Drainage Group 2 (at four application times). In the remaining plots the emission factor of a Group 2 substance was calculated by multiplying with the ratio between emissions in that plot and the reference plot, the average emission factor for all 48 Group 1 substances.

#### Emission indicator

The emission indicator for drainage is calculated as the soil deposition rate multiplied with the emission factor for the application time in the GeoPEARL model. For substances with emission factors obtained with GeoPEARL 4 model simulations (Drainage Group 1):

$$E_{dr} = S_N M_{dr} \quad \text{Equation 27}$$

$E_{dr}$  emission by drainage flow towards field ditches ( $\text{kg ha}^{-1}$ )  
 $S_N$  net soil deposition rate in the plot (Equation 4) ( $\text{kg ha}^{-1}$ )  
 $M_{dr}$  annual mass in drainage flow, per unit area of agricultural land and per unit soil deposition rate ( $\text{kg ha}^{-1} / (\text{kg ha}^{-1})$ )

And for substances with emission factors obtained with the meta model (Drainage Group 2):

$$E_{dr} = S_N f_{UC} M_{dr,ref} \quad \text{Equation 28}$$

$$f_{UC} = \frac{1}{n} \sum_{i=1}^n \frac{M_{dr,UC,i}}{M_{dr,ref,i}}$$

*Equation 29*

With:

$E_{dr}$	emission by drainage flow towards field ditches (kg ha <sup>-1</sup> )
$S_N$	net soil deposition rate in the plot (Equation 4) (kg ha <sup>-1</sup> )
$f_{UC}$	drainage factor for the substance plot combination (-)
$n$	the number of substances with emission factors simulated with GeoPEARL 4 (n = 48).
$M_{dr,UC,i}$	annual mass in drainage flow for plot UC and substance i, per unit area of agricultural land and per unit soil deposition rate (kg ha <sup>-1</sup> ) / (kg ha <sup>-1</sup> )
$M_{dr,ref,i}$	annual mass in drainage flow for the reference plot and substance i (kg ha <sup>-1</sup> ) / (kg ha <sup>-1</sup> )
ref	suffix denoting reference plot 4550

### 3.2.4 Point sources

In this section the emission indicators for point source emissions resulting from applications in arable crops and in mushroom cultivation are given.

The emission indicators for applications at the farm yard consider the direct losses and runoff during or following the disinfection treatment of flower bulbs and other plant materials, and the discharge of condensation water with substance from treatment of flower bulbs in storage buildings (Chapter 1). For both combinations of object treated and application method, a constant emission factor was derived from the limited data available;

$$E_{sw,rf} = A f_{rf}$$

*Equation 30*

$E_{sw,rf}$	emission by runoff from farm yards (kg ha <sup>-1</sup> )
$f_{rf}$	emission factor for direct losses and runoff from farm yards after disinfection treatment of flower bulbs and other plant materials (= 0.14%, Van der Linden et al., 2006) (-)
A	application rate (kg ha <sup>-1</sup> )

And;

$$E_{sw,sb} = A f_{sb}$$

*Equation 31*

$E_{sw,sb}$	emission by discharge form storage buildings (kg ha <sup>-1</sup> )
$f_{sb}$	emission factor for the discharge of condensation water with substance from treatment of flower bulbs in storage buildings (= 0.00173%) (-)
A	application rate (kg ha <sup>-1</sup> )

The farm yard where these losses may take place is assumed to be at the location of the crop field. There is no specific information available from the surveys about the location where these treatments take place.

Point source emissions resulting from applications in mushroom cultivation are calculated based on an inventory conducted at the end of the previous, 1<sup>st</sup> policy period (Liefijm et al., 2000). Mushrooms are assumed to be cultivated in closed buildings. The fraction of the amount applied which dissolves in the

condensation water depends on the product group. Emission is calculated at 89% of the cultivated area, with condensation water collected to be discharged towards surface water at a later moment. It is assumed that the concentration in the collected condensation water reduces with 50% due to degradation, during the period between application and the moment of discharge:

$$E_{sw,mc} = A f_{mc} o_{mc} (1 - f_c) \quad \text{Equation 32}$$

$E_{sw,mc}$	emission by discharge from buildings used for mushroom cultivation (kg ha <sup>-1</sup> )
A	application rate (kg ha <sup>-1</sup> )
$f_{mc}$	fraction dissolved in condensation water ( $f_{mc} = 0.015$ for insecticides, 0.01 for fungicides, and 0.0025 for other product groups) (-)
$o_{mc}$	area fraction of buildings used for mushroom cultivation with the condensation water collected in a sink, resulting in emission (= 0.89) (-)
$f_c$	reduction factor for degradation during the period between application and the moment of discharge (= 0.5) (-)

### 3.2.5 Discharge from greenhouses with soilless cultivation

#### *Introduction*

According to (Vermeulen et al., 2010) the main emission pathways to surface water from Dutch greenhouses are (1) discharge of recirculation water in case of soilless cultivation on artificial substrate or pot plant cultivation on tables, and (2) leaching in case of soil bound cultivation with crops rooting in greenhouse soil. These two cultivation types cover the vast majority of the covered crop area in the Netherlands.

Emissions from greenhouses depend largely on the application method and the cultivation system. The NMI 3 includes three modules for different combinations of soilless cultivation and application method (Chapter 1). Although these modules focus on the emission to surface water, the modules for spraying applications also calculate emission to the air. An overview of the emissions to this environmental compartment is given in Section 3.4.

For soilless cultivation, discharge of recirculation water forms the major emission route towards surface water. The driving forces behind these discharge events are the sodium content in the recirculated nutrient solution and the sodium tolerance of the greenhouse crop (Vermeulen et al., 2010). Hence, the quality of the irrigation water has a large effect on the total emitted mass of PPP to surface water. Irrigation water quality is in its turn determined by e.g. the volume of the rainwater collector, total annual rainfall and the quality of the alternate irrigation water in case the rainwater collector has been depleted. In addition to the sodium content in the nutrient solution, the application method, the size and timing of the application as well as substance degradation in the recirculated nutrient solution determine to a large extent the loadings to surface water.

For soilless cultivation systems, the procedure for calculating the emission indicator resulting from a national average application involves two steps. After selection of a model greenhouse crop and the corresponding estimated water fluxes within a greenhouse (Step 1), the calculation of the daily substance emission rate into surface water is performed with a simulation model built into the NMI 3, as will be described in this section (Step 2). This simulation model uses no spatial input data on climate, soil or surface water, and therefore a single run is executed for each national average application, contrary to the procedure for applications in open field crops where emissions are calculated for each plot contributing to the area of the crop treated. This single model run results in a series of loadings, defined by the date, the volume of water and the amount of substance discharged.

The simulation model for substance flow is run with nominal application rate and with the application time, number of treatments and application interval according to the usage in the NMI database. The emission factors are defined per unit of application rate, per day and per unit of greenhouse crop area. With these results, the calculation of the exposure concentrations in surface water is performed with the field ditch dimensions defined in each plot contributing to the area of the greenhouse crop. This is described in Chapter 4.

#### *Selection of model greenhouse crops and estimated water fluxes*

In NMI 3 five model greenhouse crop types are distinguished: cucumber, ficus, pepper, phalaenopsis and rose. For each of these model crop types time series are available of the estimated water fluxes between greenhouse tanks and towards surface water on a daily basis. These time series of relevant water fluxes have been generated by the *Waterstromen* model (Bezemer and Voogt, 2008) for a typical one ha greenhouse. To calculate these time series a number of assumptions have been made, e.g. about the size of the tanks and the rainwater collector (i.e. 1500 m<sup>3</sup>) and the sodium content of the suppletion water (i.e. 1.8 mmol/L). Except for rose, the maximum daily discharge to surface water was set to 12 m<sup>3</sup> ha<sup>-1</sup> (*This limit is set by the Schieland Water Authority - personal communication Theo Cuijpers*). Because of the relatively low sodium tolerance of this plant, the daily discharge to surface water is allowed to exceed this maximum value for rose. The influence of the weather on the crop water use is represented by selecting a dry year from the weather station Naaldwijk as input for the calculations.

Different parameter values and weather years can be chosen to generate alternative time series of water fluxes e.g. for sensitivity analyses, but the calculations for EDG-2010 were based on the input values for the *Waterstromen* model mentioned above. For further details about the assumptions made to estimate water fluxes within a Dutch greenhouse see (Vermeulen et al., 2010). The simulations have resulted in time series of daily water balance terms (in m<sup>3</sup> d<sup>-1</sup> ha<sup>-1</sup>) for five model greenhouse crops, which serve as input to the next step.

At dry weather conditions, the rainwater collector may become empty at an earlier stage of the growing season and so the use of suppletion water will increase. Because the suppletion water has a higher sodium content than rainwater, this will lead to a higher discharge. There is considerable variation in the size of rainwater collectors and the different tanks of the recirculation system, the quality of the suppletion water, and the recirculation practised by the greenhouse crop growers. This variation is not accounted for in the NMI 3. The values for the sodium content of the suppletion water and the size of the rainwater collector are estimators for the entire evaluation period. As a result of this approach, the spatial - and/or temporal percentile of calculated emissions to surface water is not known.

#### *Calculation of the substance behaviour in the greenhouse system*

In most cases plant protection products in soilless cultivation systems are applied in the following ways; i) with the nutrient solution, ii) by directly spraying the crop canopy, and iii) by fogging or fumigating the greenhouse air compartment.

Following (Vermeulen et al., 2010), spraying and fogging or fumigating are treated similarly and are referred to as 'Application to the crop canopy'. Furthermore, for these application methods NMI 3 distinguishes between greenhouse crops with covered roots (with the cover preventing direct exposure of the root compartment to the substance applied) and greenhouse crops with pot plants standing on flooded tables or concrete floors.

In the latter case, part of the substance deposited on the pots and on the flooding surface may dissolve in the recirculation water. Summarizing, for soilless systems NMI 3 distinguishes between three combinations of object treated and application method:

- A) Application along with the nutrient solution;
- B) Application to the crop canopy; with no exposure of the root compartment;
- C) Application to the crop canopy, pot plant cultivation; with direct exposure of the root compartment.

The combinations of five model greenhouse crop types and these three combinations of object treated and application method are given in Table 9. In the NMI 3 each application to a greenhouse crop is linked to one of these combinations for soilless cultivation, or to the soil bound application scenario described in Section 3.2.6.

**Table 9**

*Model greenhouse crops and 3 scenarios (Combinations of object treated and application method for soilless systems; the numbers 7, 8, 9 correspond with the overview of all combinations in Table 2).*

Sector	NMI greenhouse crop		Greenhouse model crop		
			Application along with the nutrient solution (A, 9)	Application to the crop canopy (B, 8)	Application to the crop canopy (pot plants) (C, 7)
Floriculture glasshouse	Alstroemeria	ALSTROEMERIA	Rose	Rose	-
	Roses	ROZEN	Rose	Rose	-
	Carnation	ANJERS	Rose	Rose	-
	Freesias	FREESIA	Rose	Rose	-
	Gerberas	GERBERA	Rose	Rose	-
	Lilies	LELIES_GLAS	Rose	Rose	-
	Orchids	ORCHIDEEEN	Phalaenopsis	Phalaenopsis	-
	Bedding plants	PERKPLANTEN	Ficus	-	Ficus
	Pot plants (flowers)	POTPLANTEN_ BLOEI	Ficus	-	Ficus
	Pot plants (green)	POTPLANTEN_ BLAD	Ficus	-	Ficus
	Chrysanthemum	CHRYSANTEN	Cucumber	Cucumber	-
Vegetables glasshouse	Cucumbers	KOMKOMMERS	Cucumber	Cucumber	-
	Radish	RADIJS	Cucumber	Cucumber	-
	Strawberries	AARDBEIEN_BT	Cucumber	Cucumber	-
	Sweet pepper	PAPRIKA	Sweet pepper	Sweet pepper	-
	Tomatoes	TOMATEN	Cucumber	Cucumber	-

For each application to a soilless cultivation system available in the usage database, daily water and mass fluxes towards surface water are calculated. The formation of metabolites is not considered in these modules.

Analogous to applications to arable crops, the indicators for applications to greenhouse crops are calculated per unit of crop area treated (1 ha). The greenhouse dimensions are expressed per unit area of crop. The cultivated greenhouse crop area is assumed equal to the greenhouse floor surface area.

The nutrient solution and substance flow in the greenhouse substrate system will be described below for each of the scenarios. The simulation model for substance flow is described in more detail in Appendix 7.



*Application along with the nutrient solution*

A schematic representation of the water flow system for this application scenario is given in Figure 16. The blue objects refer to water tanks/reservoirs and fluxes, the red objects refer to the substance applied and the pink objects refer to the nutrient solution with added substance. The values in brackets refer to the tank volume in  $m^3$ . The green objects refer to external reservoirs and compartments.

Rain that falls on the roof of a greenhouse is collected in a basin and used for watering the crops. Before use, nutrients are added in the mixing tank. Pesticides are added to the nutrient solution in the mixing tank according to the application pattern (Figure 16). From the mixing tank the water is pumped to the plants (a) via the conducts and the substrate. Water and nutrients are partly taken up by the plants and the surplus is drained to the drain water collector tank (c). The supply rate exceeds the crop water demand in order to ensure continuous flow and a homogeneous solution within the system. The solution is pumped from the drain water collector tank to the used water tank, and can be reused as long as the sodium content does not exceed the sodium tolerance level of the crop.

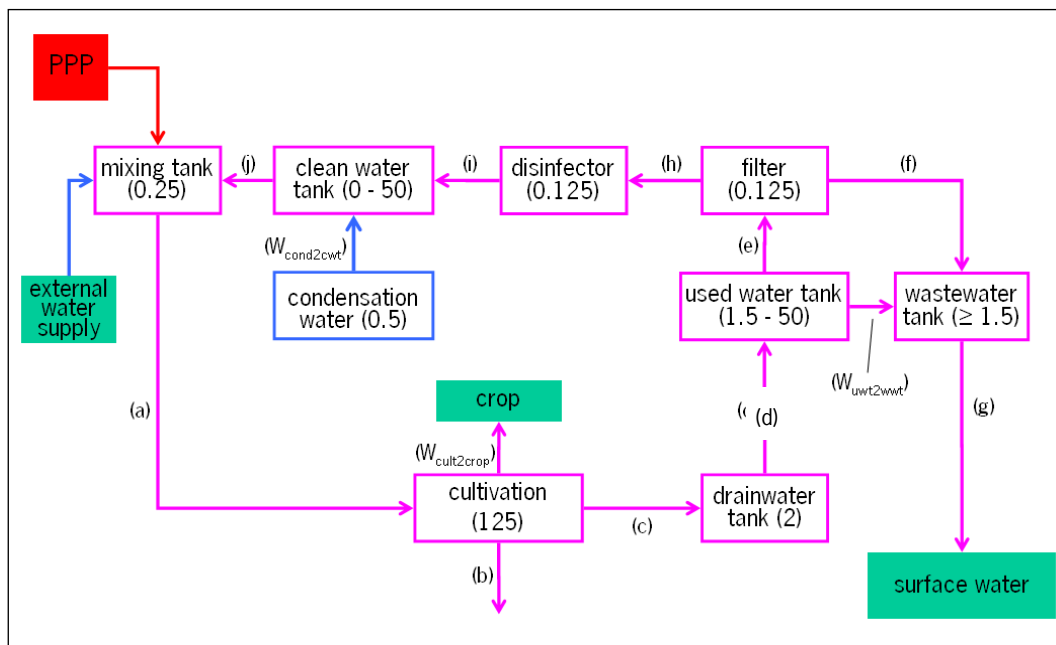

**Figure 16**

*Flow chart for the nutrient solution and substance in the greenhouse substrate system applied along with the nutrient solution. Blue objects refer to water, red objects refer to the substance applied and the pink objects refer to the nutrient solution with the substance added. The values in brackets refer to the water volume in the tanks ( $m^3$ ). Green objects refer to external reservoirs and compartments.*

The solution is pumped from the drain water collector tank to the used water tank (d). When the sodium level is below the tolerance level of the crop, the solution is filtered in the filter tank (e), disinfected in the disinfectant (h) and collected in the clean water tank (i) before it can recirculate via the mixing tank (j). When the sodium level has been exceeded, the solution is discharged to the surface water via the waste water tank (g). At these discharge events, part of the mass dissolved in the waste water resulting from filter cleaning is discharged via the waste water tank as well (f).

At the end of the growing period, the waste water tank may be (partly) filled with water and substance in solution. It is assumed that the waste water tank is emptied at the end of the growing period. In the NMI 3 the content of the waste water tank is discharged at 60 days after the last application event. During this 60 days period the substance concentration in the waste water tank decreases by degradation.

The condensation water collected from the inner side of the glass panels is added to the clean water tank. If the available rainwater in the basin is depleted, additional tap water is added to the solution. It is assumed that the greenhouse discharges directly to the surface water hence no sewage system is involved.

*Application to the crop canopy; with no exposure of the root compartment*

Figure 17 gives the schematic representation of the water and substance fluxes in case the substance is applied to the crop by spraying or fogging/fumigation. In this scenario the substrate is shielded, so there is no direct exposure of the root compartment. The shield surface is referred to as the greenhouse floor. The water flow system is similar to the water flow system in case the substance is applied with the nutrient solution. Contrary to Scenario A (Figure 16), the condensation water and the greenhouse air are considered as a single reservoir which may contain substance in solution and in the greenhouse air (vapour).

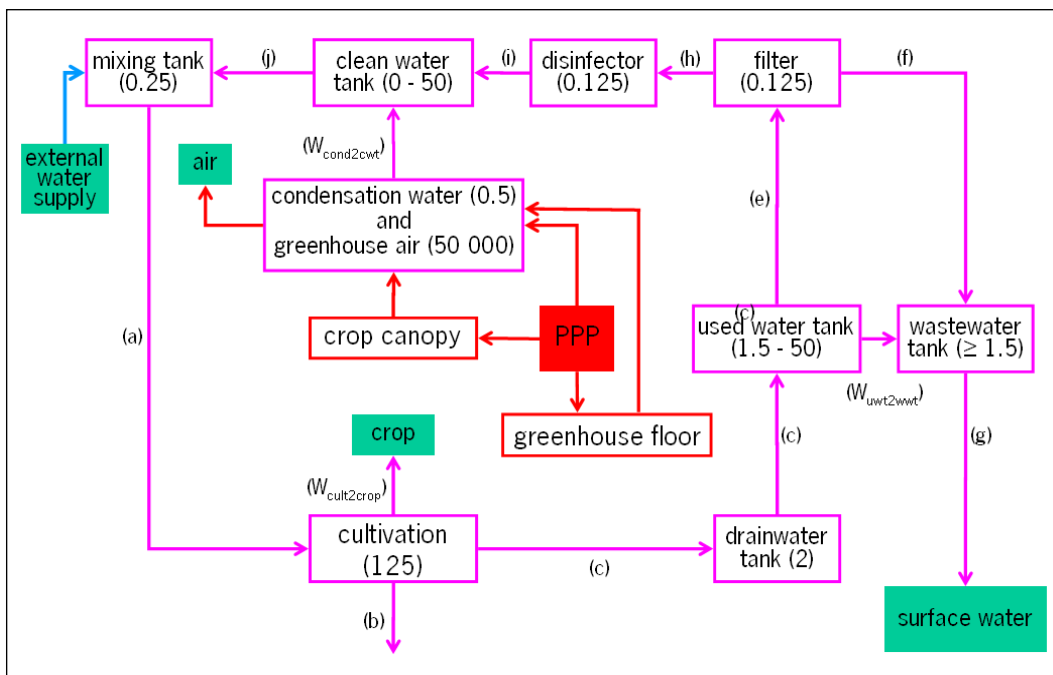

**Figure 17**

Flow chart for the nutrient solution and substance in the greenhouse substrate system applied by spraying, fogging or fumigating. The shield covering the substrate and the greenhouse soil is referred to as the greenhouse floor.

With respect to the substance behaviour, some additional storages and processes have to be taken into account compared to the applications along with the nutrient solution (Scenario A). Additional storage of substance occurs at the crop canopy, the condensation water and greenhouse air, and the greenhouse floor.

Only via condensation water that flows from the glass surface area, the sidewalls and the roofs into the clean water tank, substance may enter the nutrient solution that is recycled within the greenhouse. If the available

rainwater in the basin is depleted, additional tap water is added to the solution. It is assumed that the greenhouse discharges directly to the surface water hence no sewage system is involved. Part of substance vapour present in the greenhouse air is emitted to the air outside; a process which is assumed not to occur after application of the PPP along with the nutrient solution (Appendix 7, see also Section 3.4).

*Application to the crop canopy, pot plant cultivation; with direct exposure of the root compartment*

Figure 18 gives a schematic representation of the water and substance fluxes in case the substance is applied to the crop by spraying, fogging or fumigation, with direct exposure of the root compartment. This system refers mainly to flooded tables. The scheme is applicable to the cultivation of pot plants where the individual pots are not covered by plastic. The water flow system is similar to the flow system of the other application scenarios for soilless cultivation. The system differs from the shielded roots system in that direct application to the recirculation water forms an additional source of substance that may be emitted to the surface water.

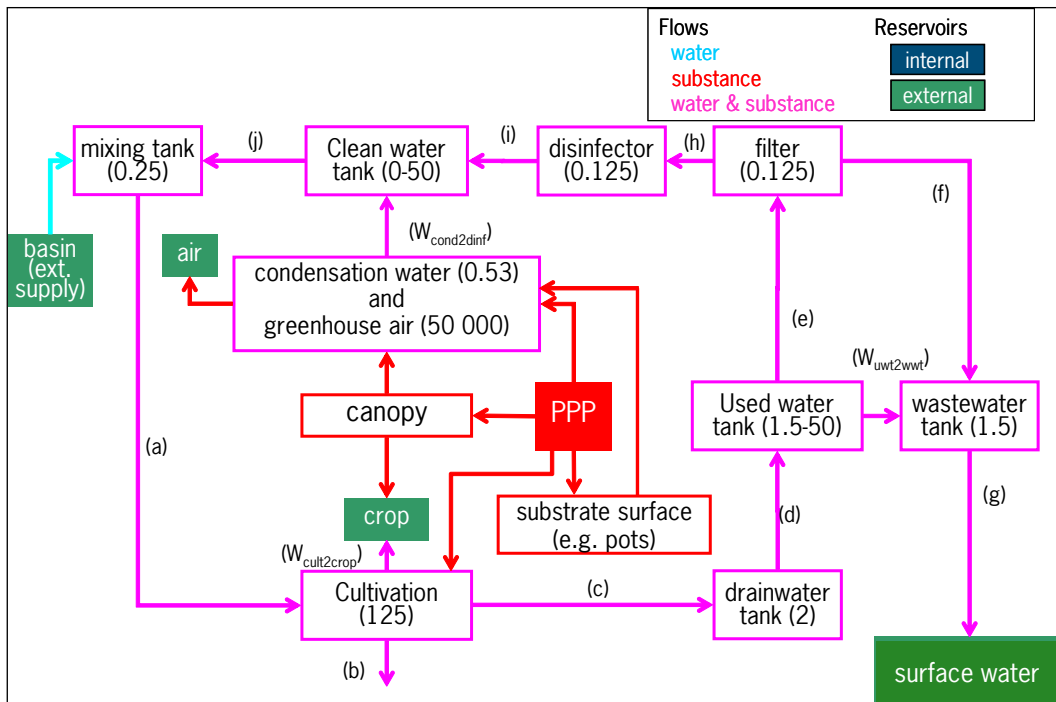

**Figure 18**

Flow chart for nutrient solution and substance for substrate system and application to the crop with direct exposure of the root compartment. The blue arrow refers to clean water, the red tank and arrows refer to substance flow or tank and the pink tanks and arrows refer to water with substance. The values in brackets refer to the volume of tanks in m<sup>3</sup>.

*Emission to surface water*

The emission resulting from applications in greenhouse crops with soilless cultivation is calculated from the nominal emission rate from the waste water tank (Appendix 7), at all events during a single growing cycle, including the emptying of the wastewater tank 60 days after the last application event:

$$E_{sw,gh} = A \sum_{t=1}^{365} J_{wwt2sw,t} \Delta t$$

**Equation 33**

With:

$E_{sw,gh}$	emission to surface water by discharge from greenhouses ( $\text{kg ha}^{-1}$ )
$A$	application rate ( $\text{kg ha}^{-1}$ )
$J_{\text{wtt2sw}}$	nominal emission rate from the wastewater tank towards surface water, per ha cultivated area ( $\text{kg ha}^{-1} \text{ d}^{-1}$ ) / ( $\text{kg ha}^{-1}$ )
$\Delta t$	duration of time step, equal to 1 day (d)

### 3.2.6 Emission from greenhouses with soil bound cultivation

In the NMI 3 all greenhouse crops rooting in the greenhouse soil are considered as soil bound cultivation systems. Surplus water with nutrients and substances can leach downwards from the greenhouse soil root zone towards deeper layers.

The module for applications to greenhouse crops with soil bound cultivation was taken from earlier versions of the NMI, with a minor adaption for calculating leaching at the bottom of the greenhouse crop root zone. The emission indicators towards surface water and towards the air outside the greenhouse are estimated based on an inventory of emission pathways conducted in 1997 (Liefijin et al., 2000). Estimated losses towards surface water result from five types of emissions:

1. discharge to surface water of substance washed off during cleaning of the interior side of the greenhouse panes;
2. discharge to surface water of substance trapped in condensation water;
3. discharge to surface water of substance leached into the soil and collected in the soil drainage system;
4. discharge to surface water of substance trapped in condensation water, which is drained onto the soil, collected in the soil drainage system and subsequently discharged;
5. discharge to surface water of substance leached into the soil and collected in the soil drainage water, which was added to the recirculation water and discharged through sluicing of recirculation water at a later stage.

The loss due to cleaning (Emission type 1) is estimated to be 0.002% of the dosage applied (Liefijin et al., 2000). At the EDG-reference period 1998, immediate discharge of condensation water (Emission type 2) was estimated to occur at 4.6% of the greenhouses (Liefijin et al., 2000), and resulted in the major part of estimated emission towards surface water (Van der Linden et al., 2006). To date, the acreage of greenhouses with no device for reuse of collected condensation water is assumed negligible. The immediate discharge of condensation water from greenhouse is therefore not considered in the development of a new tool for registration purposes. In the NMI 3 the following area fractions with immediate discharge of condensation water are assumed; 4.6% during the EDG-reference period 1998, an intermediate value of 2.3% during the EDG-period 2004, and a value of 0% during the EDG-period 2008.

Discharge of drainage water (Emission type 3) and condensation water (Emission type 4) via the greenhouse drainage system is estimated based on the area fraction of greenhouses with soil bound cultivation (Figure 9) and a drainage system (93%, Liefijin et al., 2000), the area fraction of greenhouses with soil bound cultivation and a drainage system and with reuse of collected condensation water (73,9%, Liefijin et al., 2000), and the area fraction of greenhouses with soil bound cultivation and a drainage system and with reuse of collected drainage water (10%, Liefijin et al., 2000).

**Table 10**

Fraction of the greenhouse crop area grown with soil bound cultivation. The remaining part is soilless cultivation ("-" denotes the crop is not included in the survey year).

Greenhouse sector	Crop name (NMI 3)	Survey year			
		1998	2004	2008	
Floriculture glasshouse	Alstroemeria	ALSTROEMERIA	-	0.87	-
	Roses (glasshouse)	ROZEN	0.29	0.26	0.20
	Carnation	ANJERS	0.62	-	-
	Freesias	FREESIA	0.96	1.00	1.00
	Gerberas	GERBERA	0.25	0.23	0.14
	Lilies (glasshouse)	LELIES_GLAS	0.96	0.97	0.97
	Orchids	ORCHIDEEEN	0.58	0.70	0.53
	Chrysanthemum	CHRYSANTEN	0.94	1.00	1.00
Vegetables glasshouse	Cucumbers	KOMKOMMERS	0.07	0.15	0.13
	Radish	RADIJS	-	1.00	-
	Strawberries (glasshouse)	AARDBEIEN_BT	-	-	0.53
	Sweet pepper	PAPRIKA	0.08	0.17	0.11
	Tomatoes	TOMATEN	0.06	0.15	0.11

Note that greenhouse pot plants are considered as soilless cultivation; these crops are not included in Table 4.

The emission indicator for leaching from greenhouse soil is estimated with the GeoPEARL meta model for arable crops (Section 3.3). The regression equations predict both the long-term average leaching concentration and the long-term average leaching fraction, from soil properties and average soil moisture conditions, substance properties and annual precipitation. This regression equation is used in NMI 3 for predicting leaching towards groundwater and is described in Section 3.3. Since detailed information about the conditions within a particular greenhouse is missing, leaching is calculated on the basis of meteorological and soil properties in the plots contributing to the area of the greenhouse crop. The calculated leaching fraction is increased by 0.1%, in line with the assumptions made in earlier versions of the NMI (De Nie, 2002). The calculated leaching concentration is not adjusted.

The resulting leaching fraction is used for the calculation of the losses (3) and (4) towards surface water and in the emission indicator for leaching towards deep groundwater. If drainage is present (which is the case in 93% of the greenhouse crop area with crops rooting in soil), the leaching material is captured in drains and either emitted to surface water or added to the recirculation water. If no drainage is present, the leaching material is assumed to be transported towards the groundwater.

#### *Exposure*

No scenarios are available yet to estimate the exact times that the types of emissions to surface water occur. For this reason all discharges are assumed to occur immediately after application of the substance, i.e. on the day of application. For Emission type 5 some dissipation of the substance in the recirculation water is allowed for, corresponding to a 60 day period between application and sluicing. The degradation in the recirculation water is calculated on the basis of DegT50 in water (i.e. not water/sediment) of the substance, assuming a greenhouse temperature of 20°C. Although the emission is adjusted for 60 days of dissipation, it is still assumed to occur on the day of application.

The calculated discharges to surface water are summed, resulting in a single loading into the surface water at the day of application. The calculation of acute and chronic exposure concentrations is performed analogue to the calculations performed for loadings due to spray drift from arable fields (Chapter 4).

### Usage

The applications to greenhouse crops except pot plants are split into separate applications to soil bound - and soilless cultivation systems based on the national average area fractions shown in Table 10. Pot plant cultivation is soilless by definition; the greenhouse crops in NMI 3 are listed in Appendix 5, Table 1.

The calculated leaching in soil bound greenhouse cultivation is based on the soil deposition rate. The application rate is reduced with the crop interception based on the estimated crop interception factors shown in Table 11. Note that these factors are assumed to be independent of crop height and spraying technique, contrary to the values used for field crops.

Volatilisation is estimated based on the saturated vapour class of the substance and the crop height class (Section 3.4).

**Table 11**

*Crop interception fractions depending on the method of application in greenhouses with soilbound cultivation.*

Method of application code	Description	Interception fraction (-)
DOMPEL DOMPEL_PL	Dipping of plant material	0
KAS_FOG KAS_NEVEL KAS_ROOK	Fogging or fumigating	0.5
KAS_SPBUS KAS_SPUIT KAS_STUIF KAS_VOED <sup>s</sup>	Spraying	0.75
REINIG	Cleaning window panes (interior)	0.25

## 3.3 Groundwater

The indicator for emission to groundwater is a version for the Netherlands of the GeoPEARL version 1 meta model originally developed for the European Union in the HAIR instrument (Van der Linden et al., 2007, Kruijne et al., 2011). The regression equation predicts both the nominal long-term average leaching fraction and the long-term average leaching concentration in the soil solution at 1 m depth, from soil properties and average soil moisture conditions, substance properties and annual precipitation:

$$\ln F_L = \beta_0 - \beta_1 X_1 - \beta_2 X_2$$

$$X_1 = \frac{\mu \theta L_{soil}}{q}$$

**Equation 34**

$$X_2 = \frac{\mu \rho f_{om} K_{om} L_{soil}}{q}$$

With:

$F_L$	the nominal leaching fraction at depth $L_{soil}$ , per unit soil deposition ( $\text{kg ha}^{-1}$ ) / ( $\text{kg ha}^{-1}$ )
$\mu$	the first order rate coefficient as influenced by local temperature, ( $\text{d}^{-1}$ )
$\theta$	the long term average soil water content, ( $\text{dm}^3 \text{dm}^{-3}$ )
$L_{soil}$	depth at which the leaching is evaluated, (m)
$q$	the volume flux of water at depth $L_{soil}$ , ( $\text{m d}^{-1}$ )
$\rho$	the soil dry bulk density, ( $\text{kg dm}^{-3}$ )
$f_{om}$	the fraction organic matter in the soil, ( $\text{kg kg}^{-1}$ )
$K_{om}$	the organic matter water partitioning coefficient, ( $\text{dm}^3 \text{kg}^{-1}$ )

The coefficients in Equation 34 and similarly the coefficients for the analogous concentrations in groundwater, were obtained using a dataset with results from GeoPEARL calculations for a number of hypothetical substances varying in half-life and sorption constant. From the results generated with GeoPEARL, median annual leaching values were derived for each of the plots and substances included in the calculations.  $X_1$  and  $X_2$  were calculated for all combinations using local values of the variables listed below Equation 34. Regression coefficients  $\beta$  (Table 12) were obtained using a robust linear regression technique, as included in the statistical package S-plus version 6 (see further Tiktak et al., 2007). Tiktak et al. suggest using different regression equations dependent on specific classes of combinations of precipitation and temperature. As the variation in temperature and precipitation (long term averages) is not very large for the Netherlands, it was decided not to differentiate and derive only one equation for the whole of the Netherlands. As stated above, the median fraction leached respectively the median concentration in groundwater was used as the major intention is to find out whether there are trends in leaching amounts over time. Note that Tiktak et al. derived regression constants for other leaching percentiles.

Regression coefficients  $\alpha$  (Table 12) are used for predicting the long-term average leaching concentration towards groundwater (Section 4.2).

**Table 12**

*Regression coefficients, meta models for the leaching fraction ( $\beta$ ) and for the long-term average leaching concentration ( $\alpha$ ) towards groundwater. The spring season starts in march, autumn season in September.*

Coefficient	Season	
	Spring	Autumn
$\beta_0$	-0.9890	-0.6463
$\beta_1$	0.5663	0.2230
$\beta_2$	0.5275	0.5653
$\alpha_0$	4.7529	5.1433
$\alpha_1$	0.6437	0.2650
$\alpha_2$	0.4971	0.5674

The local degradation rate coefficient,

$$\mu = \frac{\ln(2)}{DegT50_{soil}} \quad \text{Equation 35}$$

is based on the local degradation half-life in soil, adjusted for the long term annual average temperature in the meteorological region;

$$DegT50_{soil} = f_T DegT50_{soil,ref} \quad \text{Equation 36}$$

$$f_T = \exp\left(\frac{-E_a}{R} \left(\frac{1}{T_{ref}} - \frac{1}{T_a}\right)\right) \quad \text{Equation 37}$$

with

DegT50 <sub>soil</sub>	the half-life adjusted for the temperature in the plot (d)
f <sub>T</sub>	temperature correction factor (-)
DegT50 <sub>soil,ref</sub>	the half-life of the substance as listed in the substance table, (d)
E <sub>a</sub>	molar enthalpy of transformation, (J mol <sup>-1</sup> ), (54000 J mol <sup>-1</sup> )
R	molar gas constant, (J mol <sup>-1</sup> K <sup>-1</sup> ), (value 8.314 J mol <sup>-1</sup> K <sup>-1</sup> )
T <sub>ref</sub>	reference temperature, (K), (value 293.15 K ≡ 20 °C)
T <sub>a</sub>	long term average temperature in the plot (K)

According to (EFSA 2007) the default molar enthalpy of transformation E<sub>a</sub> = 65.4 kJ mol<sup>-1</sup>. Because the regression (Equation 34) is based on GeoPEARL simulations with the old default value E<sub>a</sub> = 54 kJ mol<sup>-1</sup>, this old value is used in Equation 37. The effect of the Arrhenius activation energy on the leaching concentration was shown by calculations for a number of substances, as described at the end of this section. With the old default value for the molar enthalpy of transformation the prediction of the leaching is a factor 2 lower than with the new default value.

The depth at which leaching is evaluated L<sub>soil</sub> = 1 m. The long term average, seasonal soil water content θ in this layer is calculated for the plots. It was recommended to replace these seasonal values with the long term annual soil water content, because this is in line with the leaching fraction predicted by Equation 34.

The flux of water at depth L is the precipitation surplus, derived from the long term (1981-2000) average annual water balance terms in the plot:

$$q = \frac{P + Irr - E_i - E_s - T_{act}}{365} \quad \text{Equation 38}$$

P	precipitation (m yr <sup>-1</sup> )
Irr	irrigation (m yr <sup>-1</sup> )
E <sub>i</sub>	evaporation of intercepted rainfall (m yr <sup>-1</sup> )
E <sub>s</sub>	actual soil evaporation (m yr <sup>-1</sup> )
T <sub>act</sub>	actual crop transpiration (m yr <sup>-1</sup> )



The soil bulk density in layer L is calculated with a pedotransfer function:

$$\rho = 1.8 + 1.236 f_{om} - 2.912 f_{om}^{0.5} \quad \text{Equation 39}$$

$\rho$  the soil dry bulk density, (kg dm<sup>3</sup>)  
 $f_{om}$  fraction organic matter in soil in the plot (kg.kg<sup>-1</sup>)

For substances with normal sorption behaviour, the organic matter water partitioning coefficient  $K_{om}$  at reference temperature  $T_{ref}$  is taken from the substance database. For substances with pH-dependent sorption behaviour, a combined sorption constant for the acidic molecule and its conjugated base is calculated;

$$K_{om,com} = \frac{K_{om,acid} + \frac{(MM - 1)}{MM} \cdot 10^{pH - pK_a} \cdot K_{om,base}}{1 + \frac{(MM - 1)}{MM} \cdot 10^{pH - pK_a}} \quad \text{Equation 40}$$

with

$K_{om,com}$  the combined sorption constant, (dm<sup>3</sup> kg<sup>-1</sup>)  
 $K_{om,acid}$  the sorption constant of the acidic molecule, (dm<sup>3</sup> kg<sup>-1</sup>)  
 $K_{om,base}$  the sorption constant of the conjugated base, (dm<sup>3</sup> kg<sup>-1</sup>)  
 $MM$  molar mass of the acidic molecule (g mol<sup>-1</sup>)  
 $pH$  the pH of the top soil (0-0.35 m) in the plot (-)  
 $pK_a$  the dissociation constant of the substance, (-)

In the current version of the NMI 3, the pH-shift in Equation 40 is set to 0, i.e. it is ignored. At the time of programming NMI 3 still discussion was going on the default value of the pH-shift. Also, in the Ctgbase, no values for pH-shift are listed. It is expected that the value of the pH-shift will usually be positive because of surface acidity effects. Ignoring this will then usually result in underestimation of the sorption of substance with pH-dependent sorption, at soil pH values up to two - three units above the pKa. It is expected that trends over time for an individual substance will not be affected very much as it is not expected that the areal pattern of use will change dramatically.

The indicator for emission to groundwater:

$$E_{gw} = S_N F_L \quad \text{Equation 41}$$

with

$E_{gw}$  emission to deeper groundwater in the plot (kg ha<sup>-1</sup>)  
 $S_N$  the net soil deposition in the plot (Equation 4) (kg ha<sup>-1</sup>)  
 $F_L$  the nominal fraction leaching to deeper groundwater (kg ha<sup>-1</sup>) / (kg ha<sup>-1</sup>)

#### *Effect of the default value for molar enthalpy on the predicted leaching*

The effect of the molar enthalpy of transformation (Arrhenius activation energy) on leaching was calculated for the FOCUS Kremsmünster scenario for a number of substances. The crop in the calculations was maize. The substance was applied at a rate of 1 kg ha<sup>-1</sup> one day before emergence (4 May). Calculations were made for the old and new default values of the molar enthalpy of transformation ( $E_a = 54$  and 65.4 kJ mol<sup>-1</sup>). The results in the table below indicate that the difference in leaching is about a factor two.

**Table 13**

The effect of the molar enthalpy of transformation on the predicted leaching concentrations of for substances.

Name of substance	K <sub>OM</sub> (L/kg)	DegT50 (d)	FOCUS leaching concentration (µg/L) for E <sub>a</sub> (kJ/mol)	
			54	65.4
GeoPEARL_I	10	10	0.35	0.60
XXX	10	8	0.10	0.19
GeoPEARL_N	200	120	0.62	1.11
GeoPEARL_J	70	40	0.41	0.71

### 3.4 Air

This section gives an overview of the calculated emissions to air resulting from spraying applications in arable crops and in greenhouse crops. The relevant combinations of object treated and method of application are presented in Table 5.

#### Arable crops

For spraying applications in arable crops, volatilisation to air is calculated for three routes:

1. Volatilisation during application (Section 3.1, Equation 1);
2. Volatilisation from plant;
3. Volatilisation from the soil surface.

Volatilisation from plant leaves is calculated using the regression equation (Smit et al., 1998; Smidt et al., 2000):

$${}^{10}\log(CV_{crop}) = 1.661 + 0.316 {}^{10}\log(P_{sat})$$

Equation 42

with

CV<sub>crop</sub> the cumulative volatilisation (% of amount on the crop surface)  
P<sub>sat</sub> the saturated vapour pressure of the substance (mPa), P<sub>sat</sub> ≤ 11.8 mPa

P<sub>sat</sub> is dependent on the temperature and therefore the amount volatilised is dependent on the time and the place of application, which determine the temperature (Equation 16). If P<sub>sat</sub> ≥ 11.8 mPa the cumulative volatilisation is taken to be 100%. (Substances having such a high P<sub>sat</sub> are not likely to be sprayed on crops.)

The total amount of substance volatilised from the crop, assuming no wash-off from the plants, is calculated from the amount deposited on the plant according to:

$$E_{air,crop} = \frac{CV_{crop} f_{int} (A - E_{air,app})}{100}$$

Equation 43

with

E<sub>air,crop</sub> total amount volatilised from the crop (kg ha<sup>-1</sup>)  
CV<sub>crop</sub> the cumulative volatilisation (% of amount on the crop surface)  
f<sub>int</sub> fraction intercepted by the crop (-), input from database

A application rate (kg ha<sup>-1</sup>)  
 $E_{air,app}$  emission to air during application (Equation 1), (kg ha<sup>-1</sup>)  
 100 factor to convert from % to fraction

The total amount of substance volatilised from the soil surface is calculated according to:

$$E_{air,soil} = S_{init} \frac{CV_{soil}}{100} \quad \text{Equation 44}$$

with

$E_{air,soil}$  total amount volatilised from the soil (kg ha<sup>-1</sup>)  
 $S_{init}$  initial soil deposition rate (Equation 2) (kg ha<sup>-1</sup>)  
 $CV_{soil}$  cumulated volatilisation from the soil surface (% of amount reaching the soil) (Equation 3).  
 100 factor to convert from % to fraction

The module for atmospheric deposition onto the water surface at the edge of field (Section 3.2.1) does not include any losses to air.

#### *Greenhouse crops*

For applications of PPP along with the nutrient solution it is assumed that no emissions to air occur. For spraying applications in greenhouse crops, emission towards air occurs through transport with the ventilated greenhouse air.

For spraying applications in greenhouse crops with soilless cultivation, the annual amount is calculated from the daily-emitted mass of substance via the greenhouse air (Appendix 7, Equation 19). The nominal emission rate is cumulated over the relevant days of the simulation period multiplied with the application rate, to obtain the emission to air per ha greenhouse crop:

$$E_{air,gh} = A \sum_{t=1}^{365} J_{2air,t} \quad \text{Equation 45}$$

with

$E_{air,gh}$  emission to air, per ha greenhouse crop (kg ha<sup>-1</sup>)  
 A application rate (kg ha<sup>-1</sup>)  
 $J_{2air,t}$  nominal emission rate from the greenhouse air towards the outside air, per ha cultivated area (kg ha<sup>-1</sup> d<sup>-1</sup>) / (kg ha<sup>-1</sup>)

For spraying applications in greenhouse crops with soil bound cultivation, emission towards air through transport with the ventilated greenhouse air is estimated directly from the vapour pressure class of the substance and the spraying technique (Table 14). These volatilisation fractions were taken from the module for applications in greenhouse crops in previous versions of the NMI (Liefjijn et al., 2000).

**Table 14**

*Volatilisation fraction for applications in greenhouse crops with soil bound cultivation, for five vapour pressure classes and three spraying techniques (Liefstijn et al., 2000).*

Vapour pressure class	Vapour pressure (mPa)	High volume techniques	Fogging	Low volume techniques
Low	< 0.01	0.01	0.01	0.05
Moderate	0.01 – 0.1	0.05	0.05	0.15
Average	0.1 – 1	0.10	0.25	0.25
High	1 – 10	0.30	0.35	0.35
Very high	> 10	0.40	0.40	0.40

## 4 Exposure

The conversion of emissions into exposure concentrations is performed by dividing the emitted amount of substance by the volume of the receiving compartment. Although straightforward, this approach implicitly distinguishes between emissions into receiving compartments with a fixed volume (surface water) and compartments with a volume dependent on the treated crop area (groundwater, soil).

For surface water, the receiving volume is equal to the total volume of surface water in 1 ha of the plot under consideration and hence a constant for that plot. Assuming a fixed dose rate, an increase of treated crop area will result in an increase of emission and in a corresponding increase of the concentration in surface water. In addition, assuming a fixed dose rate and a fixed crop area, an increase in the length of surface watercourses will result in a corresponding increase of emission but in an equal concentration in surface water, since emission and water volume increase to the same extent.

However, for compartments with non-fixed volumes, like e.g. soil, an increase of treated crop area will not result in a change of the concentration in soil, but will result in the 'affected' area (and volume) of soil to become larger. The increased emission is offset by an equally increased volume of affected soil, and hence the calculated concentration will remain the same (but will apply to a larger area of soil). The equations for the calculation of concentrations from emissions generally reflect this difference between these two types of compartments.

### 4.1 Surface water

Exposure concentrations in a field ditch are calculated in two distinct ways for spray drift, atmospheric deposition and point sources on the one hand and for drainage and emissions from greenhouses on the other hand. When dealing with the latter, one has to consider that such emissions are accompanied by a discharge of water, resulting in an additional dilution of the pesticide in the ditch. In contrast, no discharge of water is involved when dealing with emissions resulting from spray drift, atmospheric deposition and most point sources, and for these emission routes no additional dilution of the pesticide will occur.

Analogue to the emission factors for drainage and for two groups of substances (Section 3.2.3), the 87.5<sup>th</sup> percentile annual maximum peak- and maximum time weighted average exposure concentrations are available per plot and at four application times. For the remaining substances in the NMI database, zero drainage is assumed and the exposure in the field ditch need not be calculated. The drainage group of the substances is listed in Appendix 4.

The emission modules for atmospheric deposition, spray drift and point sources, and the exposure calculations in the NMI 3 use the field ditch dimensions and densities. These surface water data are available for three ditch classes and 22 regions and are described in Appendix 1. The exposure concentrations in a plot are calculated for the average cross-sectional profile (calculated from the dimensions and the length per ditch class). Compared to a more refined procedure for calculating the exposure concentrations in 3 separate ditch profiles, the procedure implemented in the NMI 3 may lead to underestimation of the exposure concentration in the small ditch class.

#### 4.1.1 Spray drift, atmospheric deposition and point sources

Emissions into surface water resulting from spray drift, atmospheric deposition and point sources are converted into exposure concentrations in a straightforward manner. The initial concentration in the water body immediately after application is calculated by dividing the emission (per 1 ha agricultural land) by the volume of surface water in the plot for the same 1 ha agricultural land. The concentration at any time after the application event is calculated by assuming first order dissipation (sum of degradation and evaporation) of the substance.

Since only half the volume of water is receiving the emission (wind direction factor  $\frac{1}{2}$  in Equation 23, Equation 26), the volume is also multiplied with the same factor. For atmospheric deposition and spray drift:

$$C_{sw,i}(t) = \frac{E_{sw,i}}{V \cdot \frac{1}{2}} 10^3 e^{-k_{sw}(t-t_i)} \quad \text{Equation 46}$$

with

$C_{sw,i}(t)$	exposure concentration in surface water at time/day number t (mg dm <sup>-3</sup> )
$E_{sw}$	emission to surface water (kg ha <sup>-1</sup> )
$V$	volume of surface water per unit area of agricultural land in the plot (m <sup>3</sup> ha <sup>-1</sup> )
$\frac{1}{2}$	wind direction factor (-)
$10^3$	conversion factor from (kg m <sup>-3</sup> ) to (mg dm <sup>-3</sup> ) ((mg kg <sup>-1</sup> ) (dm <sup>3</sup> m <sup>-3</sup> ))
$k_{sw}$	dissipation rate constant (d <sup>-1</sup> )
$i$	index denoting the application event number
$t_i$	day number at which application event i occurs

In the case of multiple application events belonging to the same application, a series of daily concentrations in the water body is obtained by summing the concentrations caused by each separate application event:

$$C_{sw}(t) = \sum_{i=1}^n C_{sw,i}(t) \quad \text{Equation 47}$$

$C_{sw,i}(t)$	exposure concentration at time t as a result of application event i (mg dm <sup>-3</sup> )
$C_{sw}(t)$	exposure concentration at time t resulting from all application events (mg dm <sup>-3</sup> )
$n$	the number of application events

From the information on concentrations at any time after application, the average over a time interval of 21 days is calculated for every day of the period of interest, resulting in a 21-day time weighted average (TWA) concentration.

$$TWA_{sw}(s) = \frac{1}{21} \sum_{t=s}^{t=s+20} C_{sw,i}(t) \quad \text{Equation 48}$$

The short-term exposure concentration is taken to be equal to the highest concentration occurring at any time, whereas the long-term exposure concentration is taken to be equal to the highest time weighted average concentration occurring at any time.

$$PIEC_{sw} = MAX\{C_{sw}(t)\} \quad \text{Equation 49}$$

$$TWA_{sw} = MAX \{TWA_{sw}(t)\}$$

#### Point source emissions

For point source emissions, no information is available on the time lag between the application event and the emission event(s). Therefore, the annual emission is considered as a single event which occurs at application time, and the time weighted average exposure concentration is calculated in a similar way:

$$C_{sw,i}(t) = \frac{E_{sw,i}}{V} 10^3 e^{-k_{sw}(t-t_i)} \quad \text{Equation 51}$$

$C_{sw}(t)$	exposure concentration in surface water at application time/day number t (mg dm <sup>-3</sup> )
$E_{sw}$	emission to surface water (kg ha <sup>-1</sup> )
$V$	volume of surface water per unit area of agricultural land in the plot (m <sup>3</sup> ha <sup>-1</sup> )
$10^3$	conversion factor from (kg m <sup>-3</sup> ) to (mg dm <sup>-3</sup> ) ((mg kg <sup>-1</sup> ) (dm <sup>3</sup> m <sup>-3</sup> ))
$k_{sw}$	dissipation rate constant (d <sup>-1</sup> )
$t_i$	day number at which application event occurs

The wind direction factor (Equation 46) is not used for calculating point source emissions and does not appear in Equation 41.

### 4.1.2 Greenhouses and drainage

Emissions from greenhouses are accompanied by the discharge of water, which invalidates the method described in Section 4.1.1. However, the additional dilution caused by the discharge of water can be accounted for using the method of Koopmans et al. (1990). The calculation method for ditches next to greenhouses given below also applies to the emissions resulting from drainage, but for the sake of brevity the text will only refer to emissions from greenhouses.

Emissions are converted into concentrations by assuming that the emission from a unit greenhouse crop area (= 1 ha) occurs into a standardized ditch with a length of 100 m. The volume of water contained in this 100 m ditch is calculated from the dimensions and the length of watercourses per ditch class (Appendix 1):

$$V_{ghd} = DL_{ghd} \frac{V}{L} \quad \text{Equation 52}$$

$V_{ghd}$	water volume in the greenhouse ditch (m <sup>3</sup> )
$DL_{ghd}$	length of greenhouse ditch section (= 100 m)
$V$	volume of surface water per unit area of agricultural land in the plot (m <sup>3</sup> ha <sup>-1</sup> )
$L$	length of watercourses per unit area of agricultural land in the plot (m ha <sup>-1</sup> )

The only source of water supply to the ditch is the wastewater discharged from the greenhouse. Discharge of water (and substance) is assumed to occur with a constant flow rate during a period < 24 h. The flow out of the ditch is assumed to be equal to the wastewater flow into the ditch, and the water in the ditch is assumed to be perfectly mixed, i.e. the concentration of the pesticide is the same everywhere in the ditch (and the water flowing out of the ditch is also assumed to contain this concentration of the pesticide).

The mass balance for the ditch is given by:

$$V_{ghd} \frac{dC}{dt} = Q * C_{in} - Q * C - V_{ghd} * k_{sw} * C \quad \text{Equation 53}$$

With

$V_{ghd}$	water volume in the greenhouse ditch (m <sup>3</sup> )
$C$	concentration of the substance in the ditch (mg dm <sup>-3</sup> )
$t$	time (h)
$Q$	flow (m <sup>3</sup> h <sup>-1</sup> )
$C_{in}$	concentration of the pesticide in the discharged water (mg dm <sup>-3</sup> )
$k_{sw}$	dissipation rate (degradation + volatilization) (h <sup>-1</sup> )

The solution of this first-order differential equation is given by:

$$C = C_0 \exp \left[ - \left( k_{sw} + \frac{1}{T} \right) t \right] + \frac{C_{in}}{(1 + k_{sw} * T)} * (1 - \exp \left[ - \left( k_{sw} + \frac{1}{T} \right) t \right]) \quad \text{Equation 54}$$

With

$C_0$	initial concentration in the ditch (mg dm <sup>-3</sup> )
$T$	mean residence time in the ditch, $T = V_{ghd}/Q$ (h)

Equation 54 can be solved for subsequent time steps (e.g. for each hour after the first emission event), resulting in a series of concentrations over time after the application. During the first emission event the initial concentration in the ditch is assumed to be zero, and the first term in Equation 54 does not apply. For later emission events the initial concentration in the ditch is equal to the concentration at the end of the previous time step.

Similar to what was outlined in Section 4.1.1, the average over a time interval of 21 days is calculated for every day for the period of interest, resulting in a 21-day time weighted average (TWA) concentration in the greenhouse ditch. The short-term exposure concentration in the greenhouse ditch is the highest concentration occurring at any time (within one year), whereas the long-term exposure concentration is the highest time weighted average concentration occurring at any time.

#### *Drainage*

Contrary to the exposure concentrations for atmospheric deposition, spray drift and point sources, which are calculated from the emissions, the exposure for drainage is a nominal concentration provided by the GeoPEARL (meta) model (Section 3.2.3). These 87.5<sup>th</sup> percentile, nominal concentrations in the field ditch with average dimensions and 100 m length are multiplied with the net soil deposition rate;

$$PIEC_{sw,dr} = S_N C_{dr,peak} \quad \text{Equation 55}$$

$PIEC_{sw,dr}$	short-term exposure concentration (mg dm <sup>-3</sup> )
$S_N$	soil deposition rate (kg ha <sup>-1</sup> )
$C_{dr,peak}$	annual maximum, nominal concentration in surface water (mg dm <sup>-3</sup> ) / (kg ha <sup>-1</sup> )



$$TWA_{sw,dr} = S_N C_{dr,TWA}$$

*Equation 56*

$TWA_{sw,dr}$  long-term exposure concentration (mg dm<sup>-3</sup>)  
 $S_N$  soil deposition rate (kg ha<sup>-1</sup>)  
 $C_{dr,TWA}$  annual maximum time weighted average, nominal concentration in surface water (mg dm<sup>-3</sup>) / (kg ha<sup>-1</sup>)

The short-term exposure concentration is taken to be equal to the highest annual concentration, whereas the long-term exposure concentration is taken to be equal to the highest annual time weighted average concentration.

It should be noted that the performance of this module for calculating exposure concentrations in surface water resulting from substance loadings and water supply either through the discharge from greenhouses or from pipe drains is not yet investigated thoroughly.

#### 4.1.3 Exposure concentration in water

Both spray drift, atmospheric deposition, and drainage are calculated for spraying applications in arable crops (Chapter 1). Spray drift and atmospheric deposition are assumed to occur at the same moment in time, i.e. the application event. The emission as a result of drainage may, and usually will, occur at a later moment.

Since drift and atmospheric deposition occur at the same time, the assumption is made that the exposure concentrations derived from these emissions can be summed, resulting in a combined exposure concentration for spray drift and atmospheric deposition  $PIEC_{sd+ad}$  and  $TWA_{sd+ad}$ . However, emissions through drainage result in separate values for the calculated exposure concentration in surface water,  $PIEC_{drain}$  and  $TWA_{dr}$ . Since the emissions occur at separate points in time, it does not seem realistic to estimate exposure concentration as the sum of  $PIEC_{sd+ad} + PIEC_{dr}$  and  $TWA_{sd+ad} + TWA_{dr}$ , respectively.

Assuming that the exposure concentration resulting from spray drift and atmospheric deposition on the one hand, and the exposure concentrations resulting from drainage on the other hand are independent of each other, the overall exposure concentration is assumed to be equal to the highest of either.

Thus, the short-term exposure concentration is taken to be equal to the highest peak concentration:

$$PIEC_{sw} = MAX(PIEC_{sd+ad}, PIEC_{dr})$$

*Equation 57*

whereas the long-term exposure concentration is taken as the highest time-weighted average concentration:

$$TWA_{sw} = MAX(TWA_{sd+ad}, TWA_{dr})$$

*Equation 58*

#### 4.1.4 Dissipation in water

The long-term exposure concentrations in the field ditch are calculated per plot. The first order rate coefficient for dissipation in the field ditch water body is calculated as the sum of the rate coefficient for transformation and the rate coefficient for volatilisation:

$$k_{sw} = k_{sw,deg} + k_{sw,vol} \quad \text{Equation 59}$$

$k_{sw}$  first order rate coefficient for dissipation in the field ditch ( $d^{-1}$ )  
 $k_{sw,deg}$  degradation rate coefficient in surface water ( $d^{-1}$ )  
 $k_{sw,vol}$  volatilisation rate coefficient ( $d^{-1}$ )

$$k_{sw,deg} = \frac{\ln(2)}{DegT50_{sw}} \quad \text{Equation 60}$$

The influence of temperature is given by the Arrhenius equation:

$$DegT50_{sw} = f_T DegT50_{sw,ref} \quad \text{Equation 61}$$

$$f_T = \exp\left(\frac{-E_a}{R} \left(\frac{1}{T} - \frac{1}{T_{ref}}\right)\right) \quad \text{Equation 62}$$

$DegT50_{sw}$  half-life for degradation in surface water (d)  
 $DegT50_{sw,ref}$  nominal half-life of the substance as listed in the substance table (d)  
 $f_T$  factor denoting the influence of temperature (-)  
 $E_a$  molar enthalpy of transformation ( $J mol^{-1}$ ) (default value  $54.000 J mol^{-1}$ )  
 $R$  molar gas constant ( $J mol^{-1} K^{-1}$ ) (value  $8.314 J mol^{-1} K^{-1}$ )  
 $T$  temperature at the time and place of application (K)  
 $T_{ref}$  reference temperature (K) (value  $293.15 K \equiv 20 ^\circ C$ )

It is assumed that the surface water temperature equals the average air temperature. The average daily air temperature is available for fourteen meteorological regions, and each plot is assigned to one of these meteorological regions. According to (Adriaanse et al., 1997), volatilisation from the surface water is calculated:

$$k_{sw,vol} = \frac{B}{v} \left( \frac{1}{K_l} + \frac{1}{K_g K_H} \right)^{-1} \quad \text{Equation 63}$$

$k_{sw,vol}$  volatilisation rate coefficient ( $d^{-1}$ )  
 $B$  average width of the water body in field ditches in the plot (Appendix 1) (m)  
 $v$  water volume per unit field ditch length in the plot (Appendix 1) ( $m^3 m^{-1}$ )  
 $K_l$  transport coefficient in the water phase (default  $2 m d^{-1}$ )  
 $K_g$  transport coefficient in the gas phase (default  $200 m d^{-1}$ )  
 $K_H$  dimensionless Henry coefficient (Equation 14) (-)

## 4.2 Groundwater

The long-term average leaching concentration towards groundwater is predicted with the GeoPEARL meta model, with the regression parameters  $X_1$  and  $X_2$  as described in Section 3.3 and the regression coefficients according to Table 12:

$$\ln C_L = \alpha_0 - \alpha_1 X_1 - \alpha_2 X_2 \quad \text{Equation 64}$$

$$c_{gw} = S_N C_L \quad \text{Equation 65}$$

$c_{gw}$	leaching concentration towards groundwater ( $\mu\text{g dm}^{-3}$ )
$S_N$	the net soil deposition rate (Equation 4) ( $\text{kg ha}^{-1}$ )
$C_L$	nominal leaching concentration at a unit soil deposition, ( $\mu\text{g dm}^{-3}$ ) / ( $\text{kg ha}^{-1}$ )

## 4.3 Exposure concentrations for soil organisms

### *Soil exposure concentration*

Ecotoxicological data for soil organisms which are available at the moment are based on total contents in the soil and therefore have the dimension  $[\text{M M}^{-1}]$ . Exposure concentrations therefore should be expressed in the same dimension. Input to the calculation of the exposure concentration is the net soil deposition. The net soil deposition is calculated from the nominal application rate, crop interception and several emission terms (Section 3.1, Equation 4).

The nominal application rate and the loss fractions are derived from procedures as described in Chapter 2 and in Section 3.1. The content in the soil is calculated assuming long-term use of the substance on the treated field. Potential short-term effects are evaluated after the last treatment within the growing season; potential medium term effects are evaluated two years after the last treatment and potential long-term effects are evaluated seven years after the last treatment (Van der Linden et al., 2008bc). The exposure concentrations are calculated according to the following approximation, which takes into account the amount residing in soil as a result of long term (yearly) applications, further on referred to as the plateau level, and the amount in soil resulting from the last application series. Application series is here defined as all applications of the substance within one year.

### *Plateau level*

The plateau level is calculated from the total amount reaching the soil within one growing season, the transformation of the substance and the ploughing depth. The total amount reaching the soil is calculated according to:

$$S_{N,tot} = \sum_1^n S_N \quad \text{Equation 66}$$

With

$S_{N,tot}$	the total net soil deposition within one growing season as results from an application series ( $\text{kg ha}^{-1}$ )
$n$	the number of applications within an application series (-)
$S_N$	the net soil deposition as results from an application (Equation 4) ( $\text{kg ha}^{-1}$ )

If there is only one application of the substance within a growing season,  $S_{N,tot}$  is equal to  $S_N$ .

The amount in the soil after long term applications is calculated as the lower asymptote of a saw-tooth equation:

$$M_{S,plateau} = S_{N,tot} \frac{e^{-365 f_{T,an} f_{\theta,an} k_{ref}}}{1 - e^{-365 f_{T,an} f_{\theta,an} k_{ref}}} \quad \text{Equation 67}$$

With:

- $M_{plateau}$  amount in the soil one year after the last application series of a long term treatment series (kg ha<sup>-1</sup>)
- $f_{T,an}$  function taking account of temperature effects (-)
- $f_{\theta,an}$  function taking account of soil moisture (-)
- $k_{ref}$  the first order transformation rate coefficient at reference conditions (d<sup>-1</sup>)
- 365 the number of days within a year (d)

$k_{ref}$  is calculated from the degradation half-life of the substance in soil under reference conditions. The degradation half-life is stored in the database. The half-lives refer to standard conditions, i.e. temperature 20 °C, and soil moisture in the top soil at pF2. The rate coefficient is calculated from the half-life according to:

$$k_{ref} = \frac{\ln(2)}{DegT50_{soil,ref}} \quad \text{Equation 68}$$

with

- $k_{ref}$  the first order transformation rate coefficient at reference conditions (d<sup>-1</sup>)
- $DegT50_{soil,ref}$  the degradation half-life of the substance in soil under reference conditions (d)

The influence of temperature is calculated according to the Arrhenius equation:

$$f_{T,an} = \exp\left(\frac{-E_a}{R} \left[ \frac{1}{T_a} - \frac{1}{T_{ref}} \right]\right) \quad \text{Equation 69}$$

with

- $T_a$  the local long-term annual average temperature (K)
- $T_{ref}$  the temperature at reference conditions (K) (value = 293.15)
- $R$  the gas constant (J (mol K)<sup>-1</sup>) (value = 8.31)
- $E_a$  the activation energy (J (mol K)<sup>-1</sup>)

The influence of soil moisture is calculated according to:

$$f_{\theta,an} = \min\left[1, \left(\frac{\theta_{an}}{\theta_{ref}}\right)^B\right] \quad \text{Equation 70}$$

with

- $\theta_{an}$  local annual average volumetric moisture content ( $m^3 m^{-3}$ )  
 $\theta_{ref}$  local volumetric moisture content at reference conditions (pF=2) ( $m^3 m^{-3}$ )  
B exponent (Walker, 1974) (-)

In the NMI 3, Equation 70 is not used. This decision is based on the comparisons of the annual average moisture conditions in the top layers with the reference values for the respective soils. For most soils the correction factor would be close to one. This was also found by Tiktak et al. (2006) who reported differences not larger than 5%.

The plateau content of the soil is now calculated according to:

$$C_{S,plateau} = \frac{M_{S,plateau}}{10^3 \rho_{soil} d_{pl}} 10^{-4} \quad \text{Equation 71}$$

with

- $C_{S,plateau}$  the content of the substance per kg soil resulting from long term applications, ( $kg kg^{-1}$ )  
 $d_{pl}$  the depth (thickness = 0.35 m) of the plough layer, (m)  
 $\rho_{soil}$  soil dry bulk density ( $kg dm^{-3}$ )  
 $10^3$  factor to convert  $kg dm^{-3}$  to  $kg m^{-3}$  ( $dm^3 m^{-3}$ )  
 $10^4$  factor to convert  $M_{S,plateau}$  from  $kg ha^{-1}$  to  $kg m^2 (ha m^2)$

The dry bulk density is obtained from the fraction organic matter (Equation 31). In the equations in this section the soil dry bulk density is multiplied with a factor 1000 to convert from  $kg dm^{-3}$  into  $kg m^{-3}$ . The factor  $10^4$  is used to convert from  $kg ha^{-1}$  (the unit for application rates in the database) to  $kg m^2$ . Since we are dealing with long-term periods during which ploughing occurs, the mass is expected to be distributed over the entire depth of the plough layer (0.35 m), and the concentration is calculated for this depth. Although the plough depth may be less for some tillage systems, this value is used for all applications within the scope of the risk indicators for soil. For such tillage systems with less ploughing depth the exposure may be underestimated because the substance is mixed in the model with a larger soil volume.

#### *Exposure levels*

The exposure level used for the calculation of potential acute effects is the concentration in soil immediately after the last application series. If an application series consists of a single application, the exposure level is calculated as the sum of the plateau concentration and the concentration resulting from a single application:

$$C_{S,A} = C_{S,plateau} + C_{S,i} \quad \text{Equation 72}$$

with

$$C_{S,i} = \frac{S_N}{10^3 \rho_{soil} d_{rel}} 10^{-4} \quad \text{Equation 73}$$

With:

- $C_{S,A}$  initial soil concentration after the application ( $kg kg^{-1}$ )

$C_{S,i}$	initial soil concentration resulting from the last application (kg kg <sup>-1</sup> )
$S_N$	the net soil deposition as results from an application (Equation 4) (kg ha <sup>-1</sup> )
$\rho_{soil}$	soil dry bulk density (kg dm <sup>-3</sup> )
$d_{rel}$	relevant soil depth, 5 or 20 cm depending on the application type (m)
$10^3$	factor to convert kg dm <sup>-3</sup> to kg m <sup>-3</sup> (dm <sup>3</sup> m <sup>-3</sup> )
$10^4$	factor to convert from kg ha <sup>-1</sup> to kg m <sup>2</sup> (ha m <sup>2</sup> )

The relevant soil depth is taken as 0.05 m for spraying and soil injection applications, but is assumed to be 0.20 m when the product is incorporated into the soil. The thicknesses of 5 cm and 20 cm are taken from the authorisation procedures of plant protection products. The latter value assumes that the tillage operation is down to 20 cm.

$$C_{S,i} = C_{S,i-1} e^{-f_{Tgt} k_{ref} t_{int}} + \frac{S_{N,i}}{10^3 \rho_{soil} d_{rel}} 10^{-4} \quad \text{Equation 74}$$

With:

$C_{S,i}$	initial soil concentration resulting from the last application (kg kg <sup>-1</sup> )
$C_{S,i-1}$	initial soil concentration resulting from the 2 <sup>nd</sup> last application (kg kg <sup>-1</sup> )
$f_{Tgt}$	factor for the influence of local temperature for the short period after the application (-)
$k_{ref}$	first order rate coefficient for transformation in soil, (d <sup>-1</sup> )
$t_{int}$	interval time between two applications within the growing season, (d)
$S_N$	the net soil deposition as results from an application (Equation 4) (kg ha <sup>-1</sup> )
$d_{rel}$	relevant soil depth, 5 or 20 cm depending on the application type (m)
$\rho_{soil}$	soil dry bulk density (kg dm <sup>-3</sup> )
$10^3$	factor to convert kg dm <sup>-3</sup> to kg m <sup>-3</sup> (dm <sup>3</sup> m <sup>-3</sup> )
$10^4$	factor to convert from kg ha <sup>-1</sup> to kg m <sup>2</sup> (ha m <sup>2</sup> )

$$f_{Tgt} = \exp\left(\frac{-E_a}{R} \left[ \frac{1}{T_{gt}} - \frac{1}{T_{ref}} \right]\right) \quad \text{Equation 75}$$

$f_{Tgt}$	factor for the influence of local temperature for the short period after the application (-)
$T_{gt}$	local temperature for the period after the application (therefore dependent on space and time) (K)

If the application series consists of more than one single application, the initial concentration has to be calculated for which again a sort of saw tooth approach is taken. During the application series, the residues in soil may build up. A new application adds to the remains of the former application(s). This calculator is repeated until the net soil deposition resulting from the last application has been accounted for, resulting in  $C_{S,final}$ . The initial soil concentration is then calculated as the sum of  $C_{S,final}$  and the plateau concentration  $C_{S,plateau}$ :

$$C_{s,A} = C_{S,final} + C_{S,plateau} \quad \text{Equation 76}$$

The calculation of the peak content is not straightforward. The net deposition is not constant as one or several factors, for instance interception, may vary in time. Also temperature varies in time, causing the transformation to increase (raising temperature) or decrease (falling temperature). A numerical model has

been built to calculate the peak content (amount). For all repeated applications, it is assumed that the interval period in between two applications is constant. The length of the interval period is obtained from the plant protection product use data (Section 2.1).

The peak concentration in soil (mg kg<sup>-1</sup>) is derived from the calculated C<sub>S,A</sub> in the same way for single and repeated applications:

$$PIEC_S = 10^6 C_{S,A} \quad \text{Equation 77}$$

PIEC<sub>S</sub>      peak concentration in soil (mg kg<sup>-1</sup>)  
C<sub>S,A</sub>      initial soil concentration after the application (kg kg<sup>-1</sup>)  
10<sup>6</sup>      factor to convert from kg kg<sup>-1</sup> to mg kg<sup>-1</sup> (mg kg<sup>-1</sup>)

The maximum time weighted average over a defined period is taken for calculation of short term chronic effects:

$$TWA_{soil} = \frac{1}{t_{exp}} \int_0^{t_{exp}} PIEC_S e^{-f_{Tgt} k_{ref} t} dt = \frac{PIEC_S (1 - e^{-f_{Tgt} k_{ref} t_{exp}})}{f_{Tgt} k_{ref} t_{exp}} \quad \text{Equation 78}$$

With

TWA<sub>soil</sub>      Time Weighted Average environmental concentration in soil, (mg kg<sup>-1</sup>)  
t<sub>exp</sub>      appropriate exposure time, depending on the soil organism under consideration, (d)

For the medium term and long term calculations, the amount in the soil two years respectively seven years after the last application is required. The amount present in the soil two years, respectively seven years after the last application is equal to:

$$M_{S,2y} = (M_{S,plateau} + C_{S,FINAL} 10^4 \rho_{soil\_kgm3} d_{rel}) e^{-730 f_{T,an} k_{ref}} \quad \text{Equation 79}$$

$$M_{S,7y} = (M_{S,plateau} + C_{S,FINAL} 10^4 \rho_{soil\_kgm3} d_{rel}) e^{-2555 f_{T,an} k_{ref}} \quad \text{Equation 80}$$

M<sub>S,2y</sub>      mass in soil two years after the last application (kg/ha)  
M<sub>S,7y</sub>      mass in soil seven years after the last application (kg/ha)

The concentrations in the soil at two and seven years after application are calculated according to:

$$PEC_{S,2y} = \frac{10^6 M_{S,2y}}{10^3 \rho_{soil} d_{pl}} 10^{-4} \quad \text{Equation 81}$$

$$PEC_{S,7y} = \frac{10^6 M_{S,7y}}{10^3 \rho_{soil} d_{pl}} 10^{-4} \quad \text{Equation 82}$$

$PEC_{S,2y}$  predicted environmental concentration in the soil two year after the last application (mg kg<sup>-1</sup>)  
 $PEC_{S,7y}$  predicted environmental concentration in the soil seven year after the last application (mg kg<sup>-1</sup>)

## 4.4 Exposure concentrations for terrestrial organisms (birds)

### *Introduction and scope*

Birds may be exposed in several ways: directly by spraying droplets, through the ingestion of contaminated food or drinking water, and/or through foraging on pesticide granules or treated seeds. The terrestrial risk indicators for birds in the NMI 3 consider exposure by ingestion of contaminated food items, foraging on pesticide granules and on treated seeds. These risk indicators apply to all outdoor crops and do not apply to greenhouse crops.

The terrestrial risk indicators evaluate the effect of a single or a multiple application of a pesticide on the survival of birds (acute) or in the longer term on reproduction (chronic). The method results in the calculation of Exposure Toxicity Ratio's (Chapter 5), in contrast to the toxicity exposure ratio's described in the guidance document on risk assessment for birds and mammals (EFSA, 2008).

### *Exposure*

A combination of the type of crop treated and the method of application determines the type of indicator species to be used, and the exposure level is calculated as the Daily Dietary Dose. Exposure depends on a number of properties of the species and its food items, for example body weight, physiological properties such as assimilation efficiency of the food, and moisture and energy content of the food. These factors are combined in a 'shortcut value' (Table 15). The exposure level does not depend on spatial information.

**Table 15**

*Shortcut values (SC) for residue unit doses (percentiles according to Tables IV.6 and IV.10 in EFSA, 2008).*

Nr.	Crop group	Indicator species	Short cut values for mean RUDs	Short cut values for 90 <sup>th</sup> percentile RUDs
1	Bare soils	small granivorous bird	11.4	24.7
2	Orchards and ornamentals/nursery	small insectivorous bird	18.2	46.8
3	Grassland	large herbivorous bird	16.2	30.5
4	Vinyard	small omnivorous bird	38.9	95.3
5	Bulbs and onion like crops, cereals, fruiting vegetables, leafy vegetables, legume forage, maize, oilseed rape, potatoes, pulses, root- and stem vegetables, strawberries, sugar beet, and sunflower	small omnivorous bird	64.8	158.8
6	Cotton	small omnivorous bird	65.4	160.3



#### 4.4.1 Spraying applications

For spraying applications (combinations of object treated and application method 1, 3 and 13 in Table 2) the daily dietary dose is calculated, for acute exposure:

$$DDD_{te,a} = A SC MAF \quad \text{Equation 83}$$

And for chronic exposure:

$$DDD_{te,c} = A SC MAF f_{TWA} \quad \text{Equation 84}$$

$DDD_{te,a}$	daily dietary dose, mg substance per kg body weight per day, acute (mg a.i. (kg bw) <sup>-1</sup> d <sup>-1</sup> )
$DDD_{te,c}$	daily dietary dose, mg substance per kg body weight per day, chronic (mg a.i. (kg bw) <sup>-1</sup> d <sup>-1</sup> )
A	application rate (kg a.i. ha <sup>-1</sup> )
MAF	multiple application factor, (-)
SC	crop-specific shortcut value (mg a.i. (kg bw) <sup>-1</sup> d <sup>-1</sup> ) / (kg a.i ha <sup>-1</sup> )
$f_{TWA}$	factor for conversion of acute exposure into a time weighted average exposure, (-) ( $f_{TWA} = 0.53$ at a 21-d exposure duration).

In absence of data on the degradation half-life of the substance on vegetation the time-weighted average factor  $f_{TWA}$  is calculated from a default value of 10 days and the 21-d exposure duration. For the acute risk the shortcut value (SC) for the 90<sup>th</sup> percentile Residue Unit Dose (RUD). For the chronic risk the shortcut value for the mean RUD is used (Table 15).

The multiple application factor for acute toxicity (MAF) depends on the number of treatments (Table 7, Section 4.1 in EFSA 2009). In the NMI 3 for multiple applications a MAF = 1.53 is chosen. MAF = 1 for single applications.

#### 4.4.2 Granular applications

The indicators for granular applications (combination of object treated and method of application 2, Table 3) are based on (EFSA, 2009, Chapter 5). The following types of exposure are not considered in the NMI 3 because of lack of information;

- Uptake of granules as food (EFSA, 2009, Section 5.1.1)
- Uptake of granules with other food items (5.1.5)
- Uptake with drinking water (5.1.6)

For granular applications the NMI 3 does consider;

- Uptake of granules for grit (5.1.2)
- Uptake of granules when looking for seeds (5.1.3)
- Uptake of granules with soil particles (5.1.6)

For granular applications, the daily dietary dose is calculated, for acute exposure:

$$DDD_{te,a} = A f_{gr,a} \quad \text{Equation 85}$$

and, for chronic exposure:

$$DDD_{te,c} = A f_{gc,c} f_{TWA} \quad \text{Equation 86}$$

DDD <sub>te,a</sub>	daily dietary dose, mg substance per kg body weight per day, acute (mg a.i. (kg bw) <sup>-1</sup> d <sup>-1</sup> )
DDD <sub>te,c</sub>	daily dietary dose, mg substance per kg body weight per day, chronic (mg a.i. (kg bw) <sup>-1</sup> d <sup>-1</sup> )
A	application rate (kg a.i. ha <sup>-1</sup> )
f <sub>gr,a</sub>	factor acute for generic focal species, (mg a.i. (kg bw) <sup>-1</sup> d <sup>-1</sup> ) / (kg a.i ha <sup>-1</sup> )
f <sub>gr,c</sub>	factor chronic for generic focal species, (mg a.i. (kg bw) <sup>-1</sup> d <sup>-1</sup> ) / (kg a.i ha <sup>-1</sup> )
f <sub>TWA</sub>	factor for conversion of acute exposure into a time weighted average exposure, (-). (f <sub>TWA</sub> = 0.53 at a 21-d exposure duration).

The factors f<sub>gr,a</sub> (and f<sub>gr,c</sub> for the chronic exposure) are derived from the number of granules on the soil surface and on the substance content of the granules. In (EFSA, 2009) different values for these factors are given for the exposure types mentioned in this section. Because this type of information is lacking in the national application data, it was decided to use default values f<sub>gr,a</sub> = 5500 for the acute exposure and f<sub>gr,c</sub> = 3500 for the chronic exposure. These values correspond with small granules and a granivorous bird.

#### 4.4.3 Seed treatment

For seed treatments the highest exposure level of the indicator species is reached when seed is taken up as food. It is assumed that the treated seed is the only food item of the diet. The acute exposure:

$$DDD_{te,a} = \frac{A \text{ NAR } \text{ FIR}}{bw} \quad \text{Equation 87}$$

and chronic exposure:

$$DDD_{te,c} = \frac{A \text{ NAR } \text{ FIR } f_{TWA}}{bw} \quad \text{Equation 88}$$

DDD <sub>te,a</sub>	daily dietary dose, mg substance per kg body weight per day, acute (mg a.i. (kg bw) <sup>-1</sup> d <sup>-1</sup> )
DDD <sub>te,c</sub>	daily dietary dose, chronic (mg a.i. (kg bw) <sup>-1</sup> d <sup>-1</sup> )
A	application rate (kg a.i. ha <sup>-1</sup> )
NAR	nominal application rate per kg seed, (mg a.i.) (kg seed) <sup>-1</sup>
bw	body weight of the species, (kg bw)
FIR	food intake rate, (kg seed d <sup>-1</sup> ) / (kg a.i ha <sup>-1</sup> )
f <sub>TWA</sub>	factor for conversion of acute exposure into a time weighted average exposure (-). (f <sub>TWA</sub> = 0.53 at a 21-d exposure duration).

For the nominal application rate (NAR) a default value =  $10^6$  is chosen (corresponding with 10 kg seed  $\text{ha}^{-1}$  at application rate = 1 kg a.i.  $\text{ha}^{-1}$ ).

For the indicator species considered (small granivorous bird), the ratio of the food intake rate and the body weight  $\text{FIR}_{\text{bw}}$  is a constant (Table 20, EFSA 2008), depending on the size of the granular particle. In the NMI 3 model  $\text{FIR}_{\text{bw}} = 0.30$  is chosen.



# 5 Risk indicators and aggregation

A risk indicator relates the exposure concentration to a target concentration that corresponds with the exposure regime and the species of concern. The target concentration can be either a toxic concentration or a quality standard. In the NMI 3 the risk indicator is expressed by the exposure toxicity ratio (ETR). Similar to the emission indicators in Chapter 3, the equations for surface water, groundwater, soil organisms and the terrestrial ecosystem in the first sections of this Chapter express the risk per unit area of agricultural land and these are calculated for each plot in which the crop is present. The term Environmental Indicator Units (EIUs, in Dutch *Milieu Indicator Punten/MIPs*) is used exclusively for these equations. The number of EIUs cannot be interpreted in terms of whether or not a safe concentration is exceeded.

The number of EIUs can be aggregated over plots in order to obtain risk indicators at the national scale level (Section 5.5). These indicators can be used to calculate trends and for comparing applications of similar type. The results for combinations of object treated and application method obtained with emission models based on different methodology should not be compared with each other nor be aggregated (Chapter 6).

## 5.1 Surface water

### 5.1.1 Acute toxicity

The Environmental Indicator Units for short-term (acute) exposure in surface water relates the maximum peak concentration in a plot to an acute toxic concentration:

$$EIU_{sw,a} = \frac{PIEC_{sw}}{ECC_{sw,a}} \quad \text{Equation 89}$$

with

$EIU_{sw,a}$  Environmental Indicator Units for surface water, acute (-)  
 $PIEC_{sw}$  Peak exposure concentration in the plot, acute ( $\text{mg L}^{-1}$ )  
 $ECC_{sw,a}$  Ecological Concern Concentration, acute ( $\text{mg L}^{-1}$ )

### 5.1.2 Chronic toxicity

The Environmental Indicator Units for long-term (chronic) exposure in surface water relates the maximum time weighted average concentration in the plot to a surface water quality standard:

$$EIU_{sw,c} = \frac{TWA_{sw}}{ECC_{sw,c}} \quad \text{Equation 90}$$

$EIU_{sw,c}$  Environmental Indicator Units for surface water, chronic (-)  
 $TWA_{sw}$  Time Weighted Average exposure concentration in the plot ( $\text{mg L}^{-1}$ )  
 $ECC_{sw,c}$  Ecological Concern Concentration ( $\text{mg L}^{-1}$ )

The evaluation of the operational target for risk reduction in EDG-2010 is based on the Maximum Permissible Concentration/MPC (MTR in Dutch).

## 5.2 Groundwater

The Environmental Indicator Units for the groundwater relates the long-term leaching concentration in the plot to the drinking water criterion (DWC = 0,1 µg L<sup>-1</sup>).

$$EIU_{gw} = \frac{c_{gw}}{DWC_{gw}} \quad \text{Equation 91}$$

$EIU_{gw}$  Environmental Indicator Units for groundwater, chronic (-)  
 $c_{gw}$  Leaching concentration in the plot, chronic (Equation 65) (µg L<sup>-1</sup>)  
 $DWC_{gw}$  Drinking water criterion (= 0,1 µg L<sup>-1</sup>)

## 5.3 Soil organisms

### 5.3.1 Acute toxicity

The number of Environmental Indicator Units are calculated from:

$$EIU_{soil,a} = \frac{PIEC_s}{ECC_{soil,a}} \quad \text{Equation 92}$$

$EIU_{soil,a}$  Environmental Indicator Units for soil for the acute situation, (-)  
 $PIEC_s$  Peak concentration in soil in the plot, (mg kg<sup>-1</sup>)  
 $ECC_{sw,c}$  Ecological Concern concentration, acute (mg kg<sup>-1</sup>)

### 5.3.2 Short-term chronic toxicity

$$EIU_{soil,c} = \frac{TWA_{soil}}{ECC_{soil,c}} \quad \text{Equation 93}$$

$EIU_{soil,c}$  Environmental Indicator Units for soil for the short term chronic situation, (-)  
 $TWA_{soil}$  Time Weighted Average concentration in soil in the plot, (mg kg<sup>-1</sup>)  
 $ECC_{soil,c}$  Ecological Concern Concentration, chronic (mg kg<sup>-1</sup>)

### 5.3.3 Medium term toxicity (two years)

$$EIU_{soil,2y} = \frac{PEC_{S,2y}}{ECC_{soil,2y}} \quad \text{Equation 94}$$

$EIU_{soil,2y}$  Environmental Indicator Units for soil for the situation two years after the last application, (-)  
 $PEC_{S,2y}$  Environmental Concentration in the soil two year after the last application (mg kg<sup>-1</sup>)  
 $ECC_{soil,2y}$  Ecological Concern Concentration, for a 2-year exposure period (mg kg<sup>-1</sup>)

### 5.3.4 Long term toxicity (seven years)

$$EIU_{soil,7y} = \frac{PEC_{S,7y}}{ECC_{soil,7y}} \quad \text{Equation 95}$$

$EIU_{soil,7y}$  Environmental indicator units for soil for the situation seven years after the last application, (-)  
 $PEC_{S,7y}$  Environmental concentration in the soil seven year after the last application (mg kg<sup>-1</sup>)  
 $ECC_{soil,7y}$  Ecological Concern Concentration, for the situation a seven-year exposure period (mg kg<sup>-1</sup>)

The  $ECC_{S,2y}$  and the  $ECC_{S,7y}$  may be derived according to the procedure given by Van der Linden et al. (2008bc). Sometimes assessment factors are used in the authorisation procedure of plant protection products. The NMI 3 does not explicitly account for assessment factors. If for some reason an assessment factor has to be applied, an adjusted toxicity value (ECC) has to be provided in the database.

## 5.4 Terrestrial ecosystem (birds)

The exposure level for the terrestrial ecosystem calculated as the Daily Dietary Dose (DDD) is based on exposure factors which are defined as constants (Section 4.4). The DDD per unit of agricultural land does not vary with the spatial unit (plot).

### 5.4.1 Acute toxicity

The Environmental Indicator Units for the terrestrial ecosystem is the ratio of the daily dietary dose and the lethal dose:

$$EIU_{te,a} = \frac{DDD_{te,a}}{LD50} \quad \text{Equation 96}$$

$EIU_{te,a}$  Environmental indicator units, acute, (-)  
 $DDD_{te,a}$  Daily dietary dose, mg substance per kg body weight per day, acute (mg a.i. (kg bw)<sup>-1</sup> d<sup>-1</sup>)  
 $LD50$  lethal dose 50%, mg substance per kg body weight per day, (mg a.i. (kg bw)<sup>-1</sup> d<sup>-1</sup>)

The Environmental Indicator Units for the terrestrial ecosystem is the ratio of the daily dietary dose and the No Observed Effect Dose.

### 5.4.2 Chronic toxicity

$$EIU_{te,c} = \frac{DDD_{te,c}}{NOED} \quad \text{Equation 97}$$

$EIU_{te,c}$	Environmental indicator units, chronic, (-)
$DDD_{te,c}$	Daily dietary dose, mg substance per kg body weight per day, chronic, (mg a.i. (kg bw) <sup>-1</sup> d <sup>-1</sup> )
NOED	No observed effect dose, mg substance per kg body weight per day, (mg a.i. (kg bw) <sup>-1</sup> d <sup>-1</sup> )

## 5.5 Aggregation over plots

This section describes the general equations for the aggregation of emission indicators and Environmental Indicator Units (EIUs). The term Risk Indicator is used exclusively for the result of aggregation of EIUs over space, i.e. the summation of the product of EIU and crop area over plots (the spatial units of the soil hydrological schematisation of the Netherlands).

In each plot, the emission indicator per unit area is multiplied with the area of the crop treated. The sum for all plots contributing to the crop area in the Netherlands gives the national emission indicator:

$$EI = \sum_{UC=1}^n (E_{UC} O_{cr,UC}) \quad \text{Equation 98}$$

EI	emission indicator units for a national average application in the usage database (kg)
$E_{UC}$	emission indicator in plot UC, per unit crop area (kg ha <sup>-1</sup> )
$O_{cr,UC}$	area of crop cr in plot UC (ha)
cr	index for the crop treated
n	the number of plots contributing to the crop area

In a similar way, in each plot the Environmental Indicator Units are multiplied with the area of the crop treated. The sum divided by the national crop area gives the risk indicator:

$$RI = \frac{\sum_{UC=1}^n (EIU_{UC} O_{cr,UC})}{O_{cr,NL}} \quad \text{Equation 99}$$

RI	number of risk indicator units for a national average application in the usage database (-)
$O_{cr,UC}$	area of crop cr in plot UC (ha)
$EIU_{UC}$	Environmental Indicator Units in plot UC, (-)
$O_{cr,NL}$	national area of crop cr (ha)
cr	index for the crop treated
n	the number of plots contributing to the crop area

Aggregation in the NMI 3 is done using the principles given above, over all selected items (i.e. applications, combinations of object treated and application method, substances, crops) but not over the environmental compartments. Aggregation over environmental receptors is considered not warranted scientifically, as for example the basis for the groundwater risk is totally different from the basis for surface water.



Aggregation of emissions or EIUs for a single environmental compartment is not restricted in the NMI 3, but is scientifically not always warranted either. The reason for this is the fact that models, meta models and calculation routines within the NMI 3 have a different degree of simplification. One major reason for this is the state of the art of risk assessment which is different for the sectors of agriculture in the Netherlands. For example, risk assessment for field crops is much more sophisticated than the risk assessment for point sources. Aggregation over crops and substances is always possible for a single combination of object treated and application method, because the results obtained for these applications have the same scientific basis.

Preferably, trend analyses are performed on the basis of average or median values or scenarios. Risk assessment however is usually based on conservative approaches (for example realistic worst case conditions). Because of availability of calculation rules and other data, the NMI 3 does not always use median or average approaches. The following approaches are incorporated:

- For leaching, parameters for the leaching calculations are based on median leaching over time. This approach could be followed, as median leaching concentrations were available for the whole of the Netherlands and the parameters of the meta model could be based on the median leaching concentrations.
- For drift in arable crops (and other crops treated with downward spray techniques), drift curves are based on (temporal) or 90<sup>th</sup> percentile conditions, drift curves for other percentiles were not available.
- For drift in fruit orchards and nursery trees (upward and sideways spray techniques), drift curves are available for approximately 70<sup>th</sup> percentile conditions.
- For applications in greenhouse crops, it is still unknown what percentile exposure is represented by the calculations. Research on representative scenarios is still going on.
- For the indicators on terrestrial ecosystems and soil it is also unknown what percentile is represented by the scenario, presumably average conditions are used in the soil indicator whereas small animals are chosen in the terrestrial indicator, which is a conservative approach.
- For point source emissions and resulting risks, presumably realistic worst cases are the basis for the calculations, but the actual percentiles are unknown.

Given the various approaches, the aggregation over different combinations of object treated and application method should be interpreted with great care (see also Chapter 6).

## 5.6 Trends

The spatial aggregated indicator values are used to calculate a trend over time, as the reduction percentage for indicator points over the evaluation period:

$$Trend = \left( \frac{RI_{end} - RI_{start}}{RI_{start}} \right) 100\% \quad \text{Equation 100}$$

Since the indicator units are affected by the crop area, the trend over time will also be affected by the changes in crop area over time. Aggregating indicators for national average applications can be done over applications (combination of object treated and application method), compounds, and crops.



## 6 Discussion and conclusions

The major use for which the NMI 3 is developed is the evaluation of the Dutch crop protection policy, by calculating trends in chronic risk resulting from the agricultural use of plant protection products. The absolute outcomes of emission and risk indicators at a particular moment in time (year) are less important. In addition to the emission indicators and chronic risk indicators for the aquatic ecosystem the NMI 3 also calculates indicators for other environmental compartments. The calculated risk for different species is expressed by separate indicators and these are not, and should not be summed. The indicators are intended for evaluation at the national scale and not for the local scale level.

The NMI 3 is developed using the previous version of the model NMI 2 as a starting point, and consists of a number of emission models which use a variety of input data applicable to particular combinations of the object treated and the application method in the usage data (Table 2). The risk indicators are expressed by means of an exposure toxicity ratio, and although the calculated exposure has the dimensions of concentration, it does not represent a predicted exposure concentration at the edge of field scale. For surface water, the value of the exposure toxicity ratio at a specific location and time does not express the level of risk. Whereas the NMI 2 only calculated the chronic risk indicator for spray drift resulting from applications in arable crops, the NMI 3 calculates the chronic risk indicator for all combinations of object treated and application method in the usage data. In addition to this extension of the scope of the model, a mayor modification of the model in the calculation of aquatic risk was implemented. In the NMI 2 emissions were converted into concentrations using a fixed volume of water in a one sqkm cell. In the NMI 3 the calculation of concentrations and the aquatic risk is based on a spatially variable volume of water per unit (one ha) of agricultural land.

The emission models are based on a variety of different methodologies and datasets, depending on the availability of data and tools recently developed for use in authorisation procedures. The exposure concentration in surface water resulting from spray drift is based on 70 percentile emission factors for upward and sideward spraying directions and 90 percentile emission factors for downward spraying direction. These emission factors were combined with 90 percentile factors for emission by drainage; both datasets were obtained from recently developed exposure scenarios intended for use in authorisation procedures. Although the use of 50 percentile (i.e. long-term average) emission factors is preferable for calculating trends, these data were not available for spray drift. The drift emission towards surface water will be overestimated with these 70- and 90 percentile drift emission factors, and the same applies to the drainage emission factors. Since the spray drift process is independent of substance properties it seems likely that the use of the high percentile emission factors will only have a limited effect on the calculated trend for the policy period. For the drainage process, which does depend on the substance properties, the possible effect of the percentile emission factors on the calculated trend was not investigated.

The emission factors for point source emissions from farm yards and buildings are constants with equal values for the start year and the end year of the evaluation period. This represents probably a worst case exposure scenario. Although these combinations of object treated and application method represent only a very minor portion of the total volume applied in arable crops, their contribution to the calculated emissions of particular substances in flower bulbs should not be neglected. For applications in greenhouse crops with soilless cultivation, the emission factors are based on the simulated sodium content in the recirculated nutrient solution and the sodium tolerance of the greenhouse crop. These model simulations use single values for the size of the rainwater collector and for the sodium content of the suppletion water. It is assumed that these values are representative for the major greenhouse crops and for the entire evaluation period as well. The percentile of

the exposure factors calculated with these models is not known. For applications in greenhouse crops with soil bound cultivation, the NMI 3 uses the model which was developed for the evaluation of the previous, 1<sup>st</sup> policy period, with a few minor modifications. The risk indicator is calculated for a single discharge event at a fixed date on the basis of a combination of constant emission factors and a long-term average leaching fraction. In lack of more recent data, the approach is relatively simple compared to the models for soilless cultivation. The same applies to the model for applications in buildings used for mushroom cultivation, which was also developed for the evaluation of the previous, 1<sup>st</sup> policy period.

Because of these differences in concepts and the available datasets, trends should preferably be derived only within groups of applications which belong to the same combination of object treated and application method. Each application in the NMI database is linked to a combination of object treated and application method which determines the emission pathways calculated. Summation of risk indicator units over different combinations of object treated and application methods, calculated using dissimilar models, may result in misleading conclusions about the relative importance of these combinations. Therefore, we do not advocate such summation of indicators calculated with dissimilar models. On the other hand, the national policy evaluation explicitly requires a single aggregated trend as a result of all agricultural applications. The best option in such cases is to aggregate the risk resulting from all applications in arable crops, and separately aggregating the applications in greenhouse crops with soilless cultivation and in greenhouse crops with soil bound cultivation. The greenhouse crop groups do not include mushroom cultivation.

Pesticide usage in terms of national average applications was derived from farm based surveys conducted by Statistics Netherlands. Regional based usage data were not available for use in the NMI 3. Usage described in the model in terms of national average applications differs from the applications according to the product label text, e.g. with respect to the rate applied, the application date and the number of treatments. These differences may influence the exposure levels calculated with the model. The amount of substance applied at the farms is distributed in the model over the entire crop area in the Netherlands. Since most types of usage are actually performed by only a fraction of the farms present in the survey, the national average application rate in the model input decreases with the corresponding fraction of the national crop area treated. These national average applications imply that all locations with the crop get the same treatment. As a consequence, the application rate in the model input can be much lower than the dose rate actually applied by farmers.

Because of the differences in concepts and the available datasets for calculating emissions and the nature of the national average applications in the usage dataset, the distance to target type of risk indicator, which can also be calculated with the NMI 3, is considered not suitable for the policy evaluation.

# References

Adriaanse, P.I.,(1996. Fate of pesticides in field ditches: the TOXSWA simulation model. Report 90, DLO Winand Staring Centre, Wageningen.

Adriaanse, P.I, W.H.J Beltman, E. Westein, W.W.M. Brouwer and S. van Nierop, 1997. A proposed policy for differentiated hazard evaluation of pesticides in surface water - Exposure concentrations simulated by TOXSWA and ecotoxicological hazards of pesticides in field ditches and main watercourses. Report 141, DLO Winand Staring Centre, Wageningen.

De Nie, D.S., 2002. Emissie-evaluatie MJP-G 2000. Achtergronden en berekeningen van emissies van gewasbeschermingsmiddelen. RIVM report 716601004/2002. RIVM, Bilthoven (*in Dutch*).

EFSA, 2007. Opinion on a request from EFSA related to the default Q10 value used to describe the temperature effect on transformation rates of pesticides in soil. Scientific Opinion of the Panel on Plant Protection Products and their Residues (PPR-Panel). EFSA Journal 622: 1-32.

EFSA, 2008. Risk Assessment for Birds and Mammals. Revision of Guidance Document under Council Directive 91/414/EEC (SANCO/4145/2000 – final of 25 September 2002). Scientific Opinion of the Panel on Plant protection products and their Residues (PPR) on the Science behind the Guidance Document on Risk Assessment for birds and mammals. (Question No EFSA-Q-2006-064). Adopted on 17 June 2008.

FOCUS, 2008. Pesticides in Air: Considerations for Exposure Assessment. Report of the FOCUS Working Group on Pesticides in Air, EC Document Reference SANCO/10553/2006 Rev 2 June 2008. 327 p.

Koopmans, R.W.R., W.H. van der Molen en H.C. van Ommen, 1990. Grondwaterstroming en kwaliteit. Vakgroep Hydrologie, Bodemnatuurkunde en Hydraulica. Landbouwuniversiteit Wageningen (*in Dutch*).

Kroes, J.G., P.J.T. van Bakel, J. Huygen, T. Kroon, H.Th.L. Massop and R. Pastoors, 2002. Nationwide application of a comprehensive 1D-hydrological model. In: G.J. Hunter and K. Lowell (Eds.). Proceedings of the 5th international symposium on spatial accuracy assessment in natural resources and environmental sciences (Accuracy 2002), Melbourne, 10-12 July 2002, pp. 88-93.

Kroon, T., P. Finke, I. Peereboom en A. Beusen, 2003. Redesign STONE. De nieuwe schematisatie voor STONE: de ruimtelijke indeling en de toekenning van hydrologische en bodemchemische parameters. RIZA-Rapport 2001.017 (*in Dutch*).

Kruijne, R., J. Deneer, J. Lahr and J. Vlaming, 2011. HAIR 2010 Documentation - Calculating risk indicators related to agricultural use of pesticides within the European Union, January 3, 2011, Alterra, Wageningen UR, Report 2113.1, 202 p.

Lieffijn, H., J. Deneer en M. Leistra, 2000. Schatting van de emissie van bestrijdingsmiddelen uit de glastuinbouw; Een nulmeting (1997) ten behoeve van het Milieuconvenant Glastuinbouw en Milieu, Expertise centrum LNV, Ede (*in Dutch*).

Mensink B.J.W.G., C.E. Smit, M.H.M.M. Montforts, 2008. Manual for summarising and evaluating environmental aspects of plant protection products. RIVM Report 601712004/2008.

MNP, 2006. Tussenevaluatie van de nota Duurzame gewasbescherming. Mid-term evaluation of the policy plan on sustainable crop protection. MNP, Bilthoven, The Netherlands (*In Dutch, with English summary*).

Mol., E and G.J. Wingelaar, 2010. Implementatiegraad van drift-reducerende maatregelen en technieken langs oppervlaktewater in 2008. Wageningen, 2010 (*in Dutch*).

Smit, A.A.M.F.R., F. van den Berg and M. Leistra, 1997. Estimation method for the volatilization of pesticides from fallow soil. Environmental Planning Bureau report, Series 2. DLO Winand Staring Centre, Wageningen.

Smit, A.A.M.F.R., M. Leistra and F. van den Berg, 1998. Estimation method for the volatilization of pesticides from plants. Environmental Planning Bureau series 4, DLO Winand Staring Centre, Wageningen, the Netherlands.

Smidt, R.A., A.A.M.F.R. Smit, F. van den Berg, J. Denneboom, J.C. Van de Zande, H.J. Holterman and J.F.M. Huijsmans, 2000. Beschrijving van de emissie van bestrijdingsmiddelen naar de lucht bij bespuiting van bodem of gewas in ISBEST 3.0. Rapport 207, ISSN 1566-7197, Alterra, Wageningen, the Netherlands (in Dutch).

Tiktak, A., P.I. Adriaanse, J.J.T.I. Boesten, J. Delsman, C. van Griethuysen, M.M.S. van ter Horst, J.B.H.J. Linders, A.M.A. van der Linden en J.C. van de Zande, 2011. Edge-of field scenarios for exposure of water organisms in the Netherlands. Part 1: Field crops and downward spraying. RIVM report 607407002.

Tiktak, A., P.I. Adriaanse, J.J.T.I. Boesten, R.F.A. Hendriks and A.M.A. van der Linden, 2012b. Leaching of Plant Protection Products to field ditches in the Netherlands - Development of a PEARL drain pipe scenario for arable land. RIVM Report 607407003/2011.

Tiktak, A., J.J.T.I. Boesten, A.M.A. van der Linden and M. Vanclooster. 2006. Mapping the Vulnerability of European Groundwater to the Leaching of Pesticides with a process-based Metamodel of EuroPEARL. J. Environm. Qual. 35:1213-1226.

Van der Linden, A.M.A., P. van Beelen, G.A. van den Berg, M. de Boer, D.J. van der Gaag, J.G. Groenwold, J.F.M. Huijsmans, D.F. Kalf, S.A.M. de Kool, R. Kruijne, R.C.M. Merkelbach, G.R. de Snoo, R.A.N. Vijftigschild, M.G. Vijver en A.J. van der Wal, 2006. Evaluatie duurzame gewasbescherming 2006: milieu. RIVM, Bilthoven, Rapport 607016001 (*in Dutch*).

Van der Linden, A.M.A., A. Tiktak, J.J.T.I. Boesten and M. Vanclooster, 2007. Groundwater indicators. EU Sixth Framework Programme, project HARmonised environmental Indicators for pesticides Risks, HAIR, contract number SSPE-CT-2003-501997. Report of Work Package 8, Institute for Public Health and the Environment.

Van der Linden, A.M.A, R. Luttik, J.G. Groenwold, R. Kruijne and R.C.M. Merkelbach. 2008a. Dutch Environmental Indicator for plant protection products, version 2. Input, calculation and aggregation procedures, RIVM report 607600002/2008.

Van der Linden, A.M.A., J.J.T.I. Boesten, T.C.M. Brock, G.M.A. van Eekelen, M.M.S. ter Horst, F.M.M. de Jong, M.H.M.M. Montforts and J.W. Pol, 2008b. Evaluation of the 2006 proposal for risk assessment of persistence of plant protection products in soil. De Bilt, RIVM report 601712002/2008.

Van der Linden, A.M.A., J.J.T.I. Boesten, T.C.M. Brock, G.M.A. van Eekelen, M.M.S. ter Horst, F.M.W. de Jong, M.H.M.M. Montforts and J.W. Pol, 2008c. Revised proposal for the risk assessment of persistence of plant protection products in soil. Bilthoven, RIVM report 601712003/2008.

Van der Linden, A.M.A, van der, R. Kruijne, A. Tiktak en M. Vijver, 2012. EDG-M *In preparation (in Dutch)*.

Van Puijenbroek, P.J.T.M. en J. Clement, 2010. Basiskaart Oppervlaktewater Typologie - Het oppervlaktewater in de TOP10NL geclassificeerd. PBL Rapport 500067004 *(in Dutch)*.

Vermeulen, T., A.M.A. van der Linden and E.A. van Os (eds.), 2010. Emissions of plant protection products from glasshouses to surface water in the Netherlands. Wageningen UR Greenhouse Horticulture, GTB-1002, 80 p.

Walker, A., 1974. A simulation model for prediction of herbicide persistence. J. Environ. Qual. 3:396-401.

Wingelaar, G.J., J.F.M. Huijsman and A.J.W. Rotteveel, 2001. Implementatiegraad Emissiereducerende Maatregelen in de Open Teelten - Stand van zaken voor het jaar 2000. Verslagen en Mededelingen nr. 212, PD en IMAG, Wageningen *(in Dutch)*.

Van de Zande, J.C. van de H.J. Holterman and J.F.M. Huijsmans, 2011. Spray drift for the assessment of exposure of aquatic organisms to plant protection products in the Netherlands. Report WUR-PRI, *in preparation*.



Alterra is part of the international expertise organisation Wageningen UR (University & Research centre). Our mission is 'To explore the potential of nature to improve the quality of life'. Within Wageningen UR, nine research institutes – both specialised and applied – have joined forces with Wageningen University and Van Hall Larenstein University of Applied Sciences to help answer the most important questions in the domain of healthy food and living environment. With approximately 40 locations (in the Netherlands, Brazil and China), 6,500 members of staff and 10,000 students, Wageningen UR is one of the leading organisations in its domain worldwide. The integral approach to problems and the cooperation between the exact sciences and the technological and social disciplines are at the heart of the Wageningen Approach.

Alterra is the research institute for our green living environment. We offer a combination of practical and scientific research in a multitude of disciplines related to the green world around us and the sustainable use of our living environment, such as flora and fauna, soil, water, the environment, geo-information and remote sensing, landscape and spatial planning, man and society.

More information: [www.alterra.wur.nl/uk](http://www.alterra.wur.nl/uk)